

XCELLENCE SERIES

X210 / X215W / X218W / X218W3K Systems



Copyright © 2014
All rights reserved

Pol. Ind. Norte - Perpinyà, 25
08226 TERRASSA (Barcelona-SPAIN)
info@master-audio.com
www.master-audio.com

March 14
User's manual

ENGLISH



WARNING:
To reduce the risk of fire or electric shock do not expose this equipment to rain or moisture



Safety Instructions

1. All safety instructions must be read before using this device.
2. The exclamation mark in the triangle indicates internal components which if replaced can affect safety.
3. The lightning symbol within the triangle indicates the presence of dangerous uninsulated voltages.
4. This device must not be exposed to rain or humidity.
5. Only clean the device with a dry cloth.
6. Do not situate the equipment where its ventilation system might be interfered with.
7. Do not install the device near heat sources such as radiators, heaters or other heat-emitting elements.
8. The equipment must be repaired by qualified technical service personnel when:
 - A. The mains supply cable is damaged, or
 - B. Any object or liquid has damaged the device; or
 - C. The equipment does not function normally or correctly; or
 - D. The equipment has been exposed to the rain; or
 - E. The chassis is damaged
9. Disconnect the device in the case of electric storms or during long periods of disuse.
10. Never hang the equipment by its handle.
11. Only use manufacturer recommended accessories.

1. INTRODUCTION

1.1. General product information

Master Audio thank you for the trust placed in our **Xcellence** loudspeaker systems.

The Line Array Xcellence models combine the benefits of their high quality sound transducers, the convenience of a self-powered system and the flexibility of the DSP (digital system processing) for cabinet control.

More than 38 years' experience in amplifier and acoustic cabinet design using the highest technology and components come together to give you a product ideal for a multitude of applications, specially those which require high levels of sound pressure and a control of vertical coverage. Stadiums, theatres or big events will become the perfect places for their use.

We suggest you read the following information with attention, assured that it will be of maximum use in helping you to achieve the best results and optimum performance.

1.2. What is a line array?

The trend in sound reinforcement has been to increase both the sound pressure level (SPL) and the size of the audience to be covered. This leads to an increase in the number of cabinets and, as a result of this, an increase in the total size and weight.

A line array is a group of independent sound sources which are vertically stacked in order to transform the spherical wavefronts generated by individual sources into a single flat wavefront.

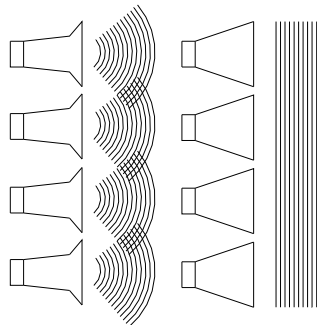

Fig.1. Wavefield interference for different wavefronts.

To carry out effectively arraying individual sound sources the system must follow the acoustic coupling conditions based on the wavelength, the shape of each source, the surface area of each transducer and the relative source separation.

An assembly of individual sound sources arrayed with regular separation between the sources on a plane or curved continuous surface is equivalent to a single sound source having the same dimensions as the total assembly if the following conditions are fulfilled:

- 1) The step of source separation, defined as the distance between the acoustic centres of the individual sources, is smaller than half the wavelength over the bandwidth of operation.

$$d \leq \lambda/2$$

It is not difficult to fulfil this first condition for the low and mid frequencies. For example, two 7" loudspeakers that are separated by 17 cm will reproduce a cylindrical wave up to 1015 Hz.

This condition is difficult to be fulfilled for the high frequencies, as their wavelengths are too small to make the adjacent acoustic centres any smaller than $\lambda/2$. Here comes the second "arrayability" criterion.

2) The wavefronts generated by the individual sources are planar and the combined surface area of the sources fills at least 80% of the total target surface area:

$$H_1 \cdot W + H_2 \cdot W + \dots + H_n \cdot W \geq 0.8 \cdot H \cdot W$$

This is achieved by using waveguides, which are coupled to the compression drivers output. We achieve flat wavefronts with a constant phase. By vertically assembling these waveguides we fulfil the second criterion of line array construction.

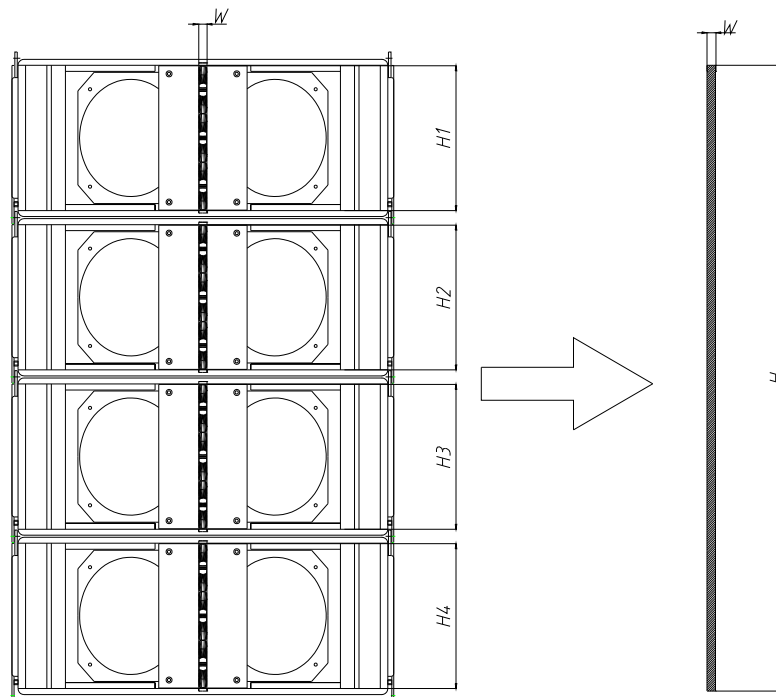

Fig.2. Second criterion of "arrayability"

3) The deviation from a flat wavefront must be less than $\lambda/4$ at the highest operating frequency (this corresponds to less than 5 mm curvature at 16kHz).

This third condition can be explained through our property waveguide. Thanks to some complex mathematical calculations we have obtained a component which is able to adapt the circular section of the compression driver to a rectangular section, getting on-phase waves at the end of the guide. This flat wavefront is ideal for vertical configurations.

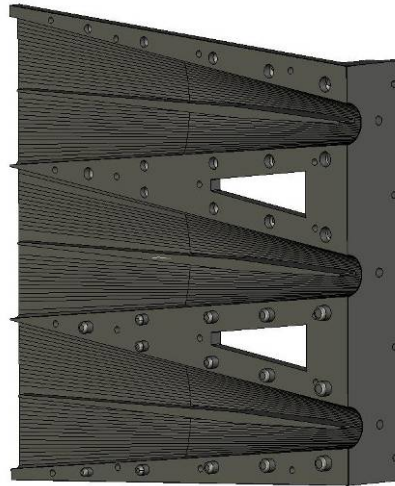

Fig.3. High frequency waveguide (half piece)

Sound engineers use line arrays to obtain narrow directivities on the vertical plane. For configurations with many cabinets (big height) and at high frequencies it is not unusual to achieve narrow angles- in some cases they may be grade fractions. This can be useful in venues where both a high sound pressure level and long throw are required; nevertheless, this means less coverage of the audience area.

It is sometimes useful to achieve an asymmetrical coverage pattern on the vertical plane, which can be obtained by aiming some of the cabinets through their hinging points. We are now ready to define the last two criteria of "arrayability".

4) For curved arrays, the tilt angles should vary in inverse proportion to the listener distance (this is geometrically equivalent to shaping variable curvature arrays to provide equal spacing of individual element impact zones).

5) There are limits given the vertical size of each cabinet and their relative tilt angles. In our case the maximum tilt angle (between cabinets) is 6° .

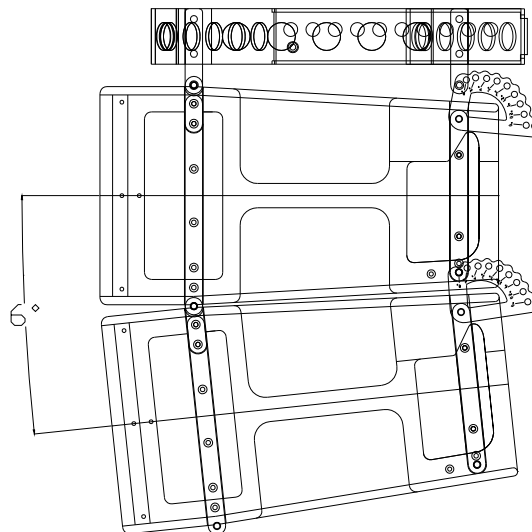

Fig.4. Tilt angle between cabinets (6° maximum)

1.3. Fresnel Region (Near Field) and Fraunhofer Region (Far Field)

As our system is able to fulfil the previous conditions it will produce cylindrical waves to a maximum frequency. The wave will be flat up to a certain distance where it will start to become spherical (depending on the frequency and the size of the array).

The limit distance between the zone of cylindrical waves (Fresnel) and spherical waves (Fraunhofer) can be calculated through the following formula

$$d_c = \frac{3}{2} H^2 f \sqrt{1 - \left(\frac{1}{3Hf} \right)^2}$$

where

d_c = limit distance between near field and far field (in metres)

H = height of the array (in metres)

f = frequency (in kHz)

In the near field region (Fresnel), the wavefront is cylindrical and waves only expand on the horizontal plane (120° in X210). The height of the wavefront is, in this case, the total height of the array.

In the far field region (Fraunhofer), the wavefront is spherical and expands both on the horizontal and vertical planes. The horizontal coverage is 120° and the vertical coverage is defined by the frequency and the height of the array.

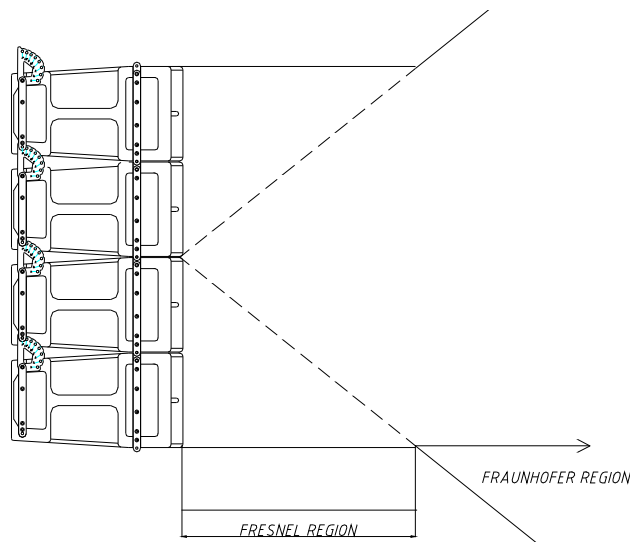

Fig.5. Limits of Fresnel-Fraunhofer Regions

We can create a chart with some of the basic configurations and their performance regarding wave propagation.

Freq (Hz)	2x X210 d _c (m)	4x X210 d _c (m)	8x X210 d _c (m)	12x X210 d _c (m)
100	Spherical	Spherical	Spherical	0.99
125	Spherical	Spherical	Spherical	1.88
250	Spherical	Spherical	2	4.97
500	Spherical	1	4.56	10.48
1k	0.5	2.28	9.38	21.21
2k	1.14	4.69	18.88	42.55
4k	2.34	9.44	37.84	85.16
8k	4.72	18.9	75.71	170.4
10k	5.9	23.65	94.64	213

Fig.6. d_c Calculation

An 8-cabinet array has a near field extending to 19 metres at 2kHz. Beyond this distance the wavefront will be spherical.

In the first zone (Fresnel), sound pressure loss is only 3 dB per doubling of distance, whereas in the second zone (Fraunhofer) the loss is 6 dB. In long throw and high SPL configurations it is very important to produce cylindrical waves.

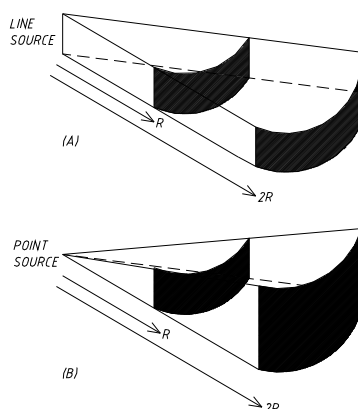

Fig.7. Cylindrical wave (A) vs Spherical wave (B)

- (A): -3 dB / doubling of distance
- (B): -6 dB / doubling of distance

1.4. Features and appearance

X210A

- Self-powered acoustic system.
- 2400W amplifier for low-mid range.
- 600W amplifier for mid-high range.
- 24-bit AD/DA converters with 112dB dynamic range, 96kHz sampling rate.
- DSP Controls (parametrics, delay, volume and limiters).
- Self amplifier diagnostics: output power, temperature, clipping.
- Ethernet connectivity.
- Overvoltage protection (>250V-400V).

- Two 10" woofers in neodymium (2.5" voice coil).
- Three 1.7" voice coil diameter, 1" exit PEN diaphragm compression drivers.
- High frequency planar waveguide design.
- 120° horizontal directivity.
- Birch plywood construction.
- Black textured Polyurea paint finish: totally ecological.
- Frontal steel grilles with acoustically transparent grey cloth.

X210P

- Passive acoustic system.
- Two 10" woofers in neodymium (2.5" voice coil).
- Three 1.7" voice coil diameter, 1" exit PEN diaphragm compression drivers.
- High frequency planar waveguide design.
- 120° horizontal directivity.
- Birch plywood construction.
- Black textured Polyurea paint finish: totally ecological.
- Frontal steel grilles with acoustically transparent grey cloth.

X215W Subwoofer

- Self-powered cabinet.
- 2400W amplifier.
- 24-bit AD/DA converters with 112dB dynamic range, 96kHz sampling rate.
- DSP Controls (parametrics, delay, volume and limiters).
- Self amplifier diagnostics: output power, temperature, clipping.
- Ethernet connectivity.
- Overvoltage protection (>250V-400V).
- Two 15" long-excursion woofers in neodymium, 4" voice coil and demodulation rings to reduce distortion and the transitory response.
- Birch plywood construction.
- Black textured Polyurea paint finish: totally ecological.
- Frontal steel grilles with acoustically transparent grey cloth.

X218W Subwoofer

- Self-powered.
- 2400W amplifier.
- 24-bit AD/DA converters with 112dB dynamic range, 96kHz sampling rate.
- DSP Controls (parametrics, delay, volume and limiters).
- Self amplifier diagnostics: output power, temperature, clipping.
- Ethernet connectivity.
- Overvoltage protection (>250V-400V).
- Two 18" long-excursion woofers in neodymium, 4" voice coil and demodulation rings to reduce distortion and the transitory response.
- Birch plywood construction.
- Black textured Polyurea paint finish: totally ecological.
- Frontal steel grilles with acoustically transparent grey cloth.

X218W3K Subwoofer

- Self-powered.
- 3000W amplifier.
- 24-bit AD/DA converters with 112dB dynamic range, 96kHz sampling rate.
- DSP Controls (parametrics, delay, volume and limiters).
- Self amplifier diagnostics: output power, temperature, clipping.
- Ethernet connectivity.
- Overvoltage protection (>250V-400V).
- Two 18" long-excursion woofers in neodymium, 4.5" voice coil and demodulation rings to reduce distortion and the transitory response.
- Birch plywood construction.
- Black textured Polyurea paint finish: totally ecological.
- Frontal steel grilles with acoustically transparent grey cloth.

2. X210A/P. FEATURES

The X210A cabinet includes 2400W bi-amplification for the low-mid range woofers, 600W for the high range compression drivers and digital signal control by DSP. The manufacturer presets LF_XTEND, COMPACT, NEARFIELD and LONGTHROW make it easy, flexible and user-friendly.

The basic set is composed of one unit X210P (passive) and one unit of X210A (active). This last model includes all the necessary electronics to feed the X210P unit.

The result is a clean, high quality sound at full power in large sites.

2.1. Technical description

The X210A cabinet comes with DSP control, full range sound delivery thanks to its direct radiation transducers and acoustic bass reflex cabinet. As a full range system, its usable bandwidth is 70Hz-18kHz (-10dB).

It has 3000W continuous amplification (2400W + 600W), thermal protection, short circuit protection at the output, maximum power limiters on each channel, and protection against mains overvoltage. The DSP includes some presets which can be selected either accessing the cabinet's rear control panel or via the computer with Ethernet connection. The LF_XTEND preset gives a maximum flat response for full range applications (without subwoofer); COMPACT preset gives a maximum flat response for a standard configuration of four X210 and one/two subwoofers (X215W/X218W/X218W3K) and it can be also used for an 8-box configuration (central cabinets); NEARFIELD preset has -3dB in high range for the lowest cabinets in a line array; LONGTHROW preset has +3dB in high range for the highest cabinets in a long-throw configuration (8 box); STACK-2 preset gives a maximum flat response for a standard configuration of two stacked X210 on one X215W/X218W/X218W3K.

The X210A cabinets are connected using the XLR balanced connector. Mains supply is through PowerCon at 230V.

Both X210A and X210P are built in birch plywood which has a high resistance against vibrations and humidity.

High resistance weatherproof bi-component paint. The front face is protected by two 1.5 mm thick steel grilles with acoustically transparent grey cloth.

They include in-built black painted stainless steel rigging hardware and handles for an easy and comfortable transport.

2.2. Presets

The X210A includes some manufacturer presets for different types of application. The DSP system can also store up to 23 customer's presets, depending on user requirements.

P1-LF XTEND

- Flying / Stacking
- Flat response
- 4 x X210
- without subwoofer/s
- Theatres/speech
- 70Hz-18kHz (X210)

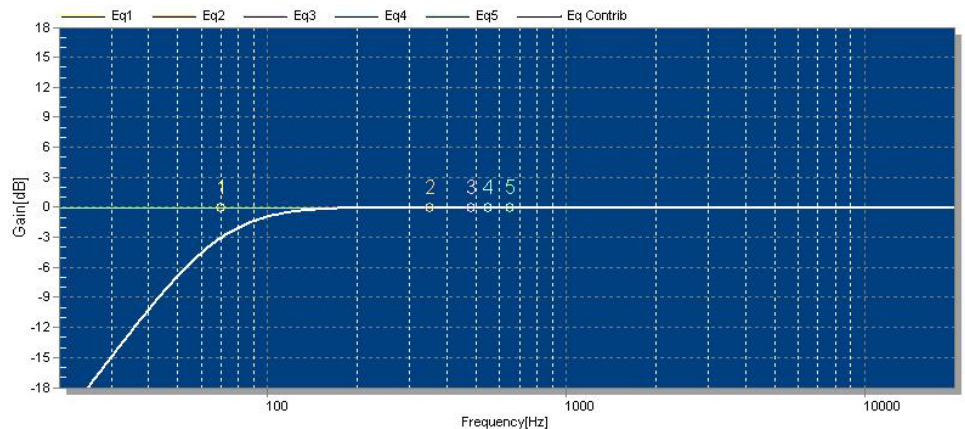

P2-COMPACT

- Flying / Stacking
- Flat response
- 4 x X210
- with subwoofer/s
- 90Hz-18kHz (X210)

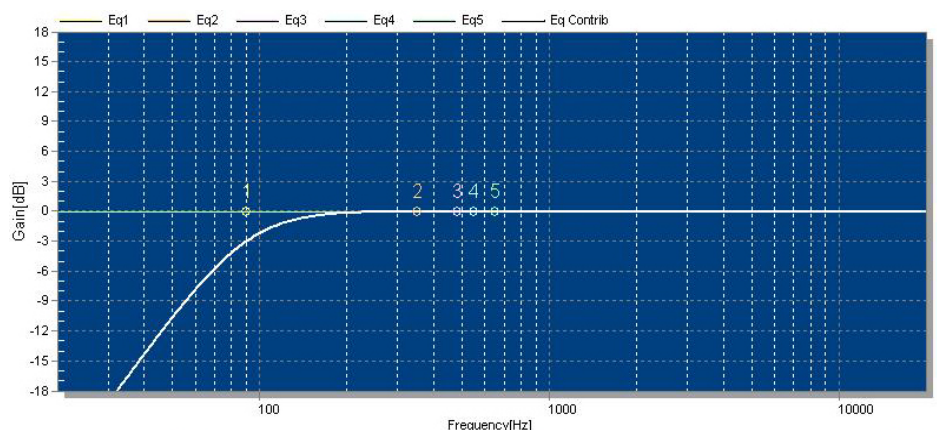

P3-NEARFIELD

- Flying / Stacking
- -3dB high range
- X210 lower cabinets
- with subwoofer/s
- 90Hz-18kHz (X210)

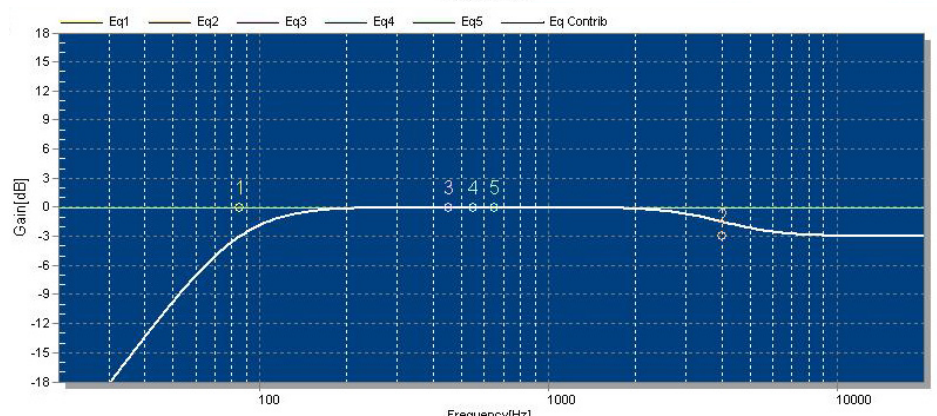

P4-LONGTHROW

- Flying / Stacking
- +3dB high range
- X210 upper cabinets
- with subwoofer/s
- 90Hz–18kHz (X210)

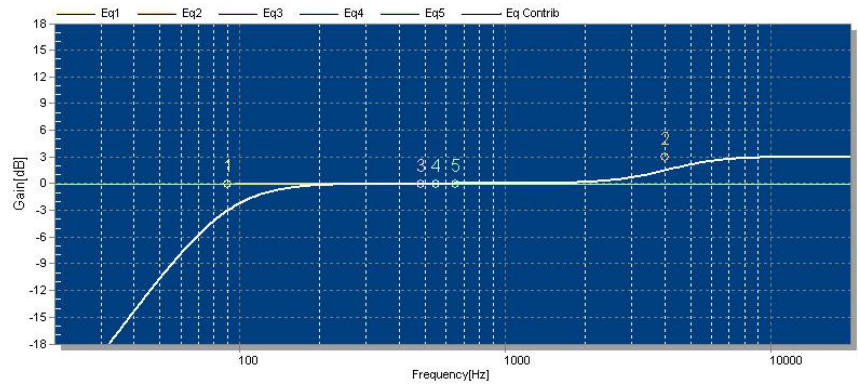

P5-STACK-2

- Stacking
- Flat response
- 2 x X210
- 1 x X218W/X218W3K
- 90Hz–18kHz (X210)

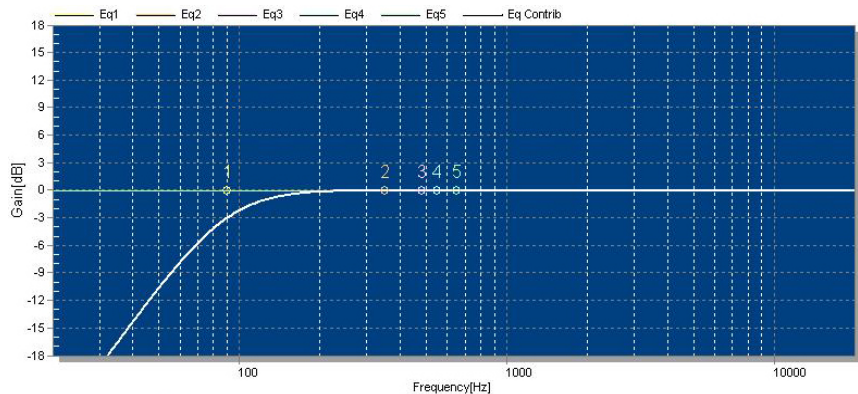
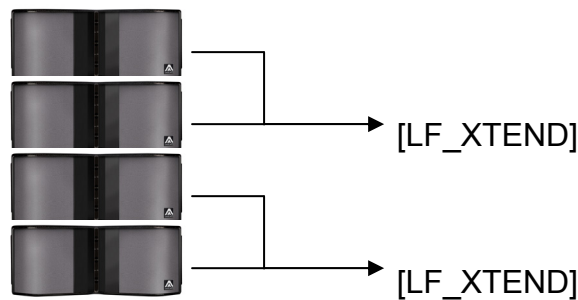

Fig.8. X210A PRESET options

EXAMPLES

4 x X210 without subwoofers

- For speech
- For background music applications at reasonable levels.



4 x X210 with X215W/X218W/X218W3K subwoofers

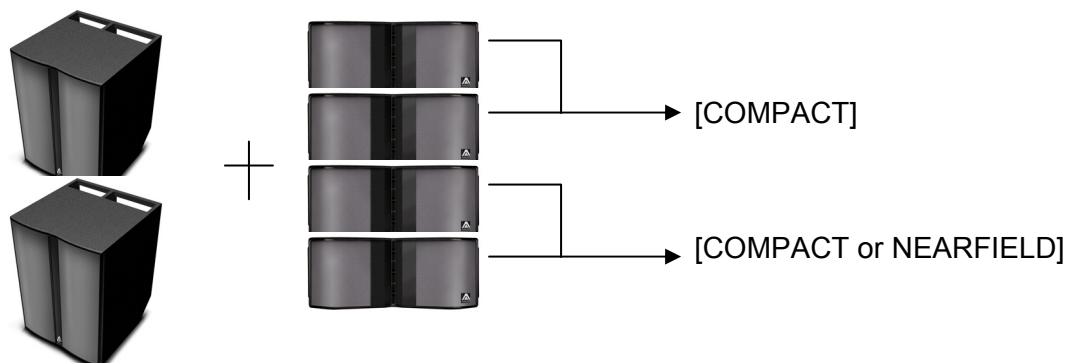

8 x X210 with X215W/X218W/X218W3K subwoofers

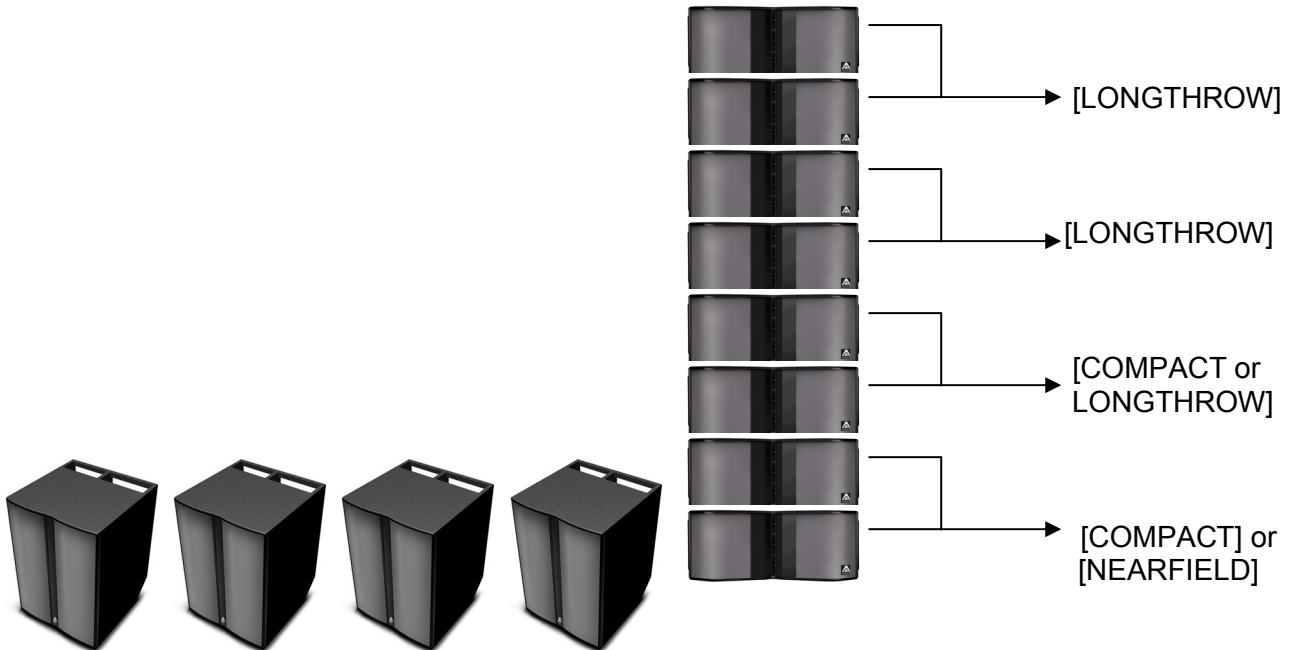

2 x X210 with 1 x X215W/X218W/X218W3K (stacking)

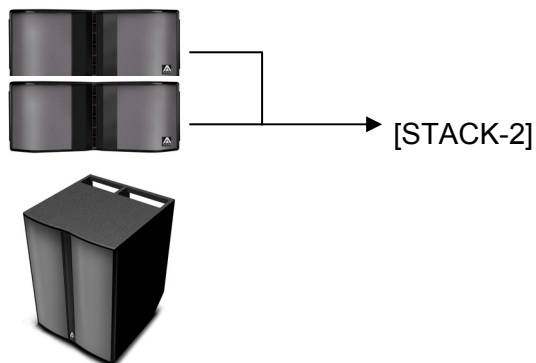

2.3. Control and Connection panel

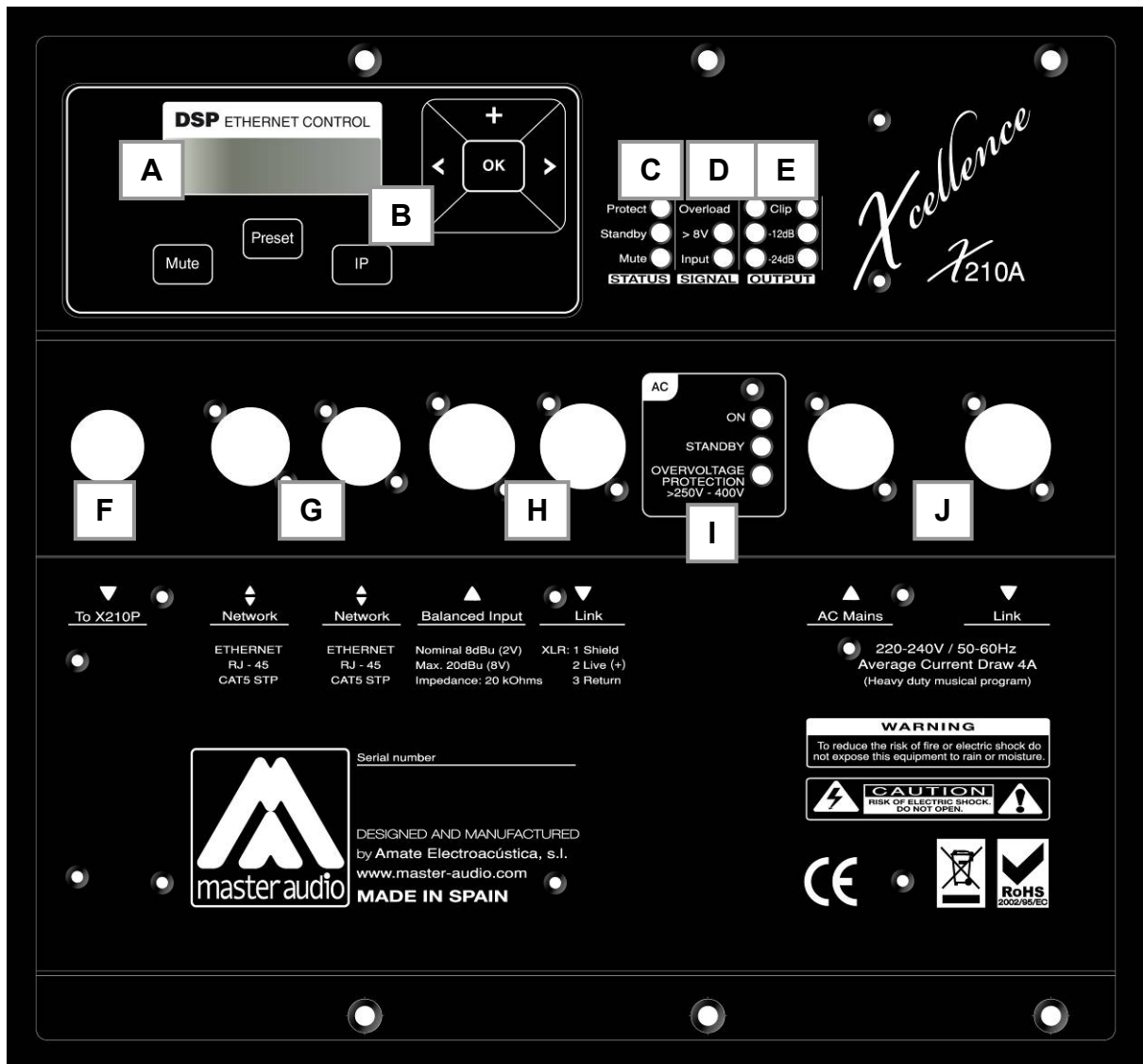

Fig.9. X210A control and connection panel

The X210A control panel contains the following elements:

A) LCD: Displays basic information about the DSP Status

B) KEYPAD: Allows the user to perform basic operations on the DSP such as IP address setting, Preset selection, etc.

C) STATUS LEDs: Report a special event happening in the system

- **Protect:** (Red) A fault condition is being reported by the amplifier. If this LED is constantly lit even after resetting the device, please contact the technical service.
- **Standby:** (Orange) This led is lit when the equipment is set in Low Power Consumption mode. This mode can only be set through the PC connection.
- **Mute:** (Orange) The system is muted (amplifiers are disabled). The system can be muted from the PC remote control or from the keypad.

IMPORTANT: When the amplifier is in MUTE, the PROTECT LED will be also lit to show that the amplifier is disabled. Also when the system is waking up from the STANDBY mode, the PROTECT led will be lit for a few seconds. Under these circumstances the PROTECT LED is reporting that the amplifier is disabled, but not a fault condition.

D) SIGNAL INPUT LEDS: Monitor the signal arriving at the module input.

- **Input:** Signal is present at the input. Nominal input level is +8dBu (2Vrms).
- **OVL D:** The input signal exceeds +14dBu (4Vrms), so it will be compressed. Avoid the continuous lighting of this led in order to preserve the dynamic range of the audio signal.

E) OUPUT LEDS: Show the amplifier output level, both for Low and High channels.

- **-24dB:** The amplifier is delivering output power at -24dB of its maximum power
- **-12dB:** The amplifier is delivering output power at -12dB of its maximum power
- **Clip:** The amplifier is delivering its maximum output power

The connection panel has the following parts:

F) SLAVE OUTPUT FOR X210P

Speakon connector used to feed one slave X210P Line Array Element. In order to assure proper operation **always follow these instructions:**

- Link only ONE unit of X210P with each X210A.
- Do not connect a loudspeaker different than X210P to this output.
- Do not change or manipulate this connector.

Misusing the slave output for X210P may lead to serious damage for all involved equipment, and will not be covered by the Warranty.

G) NETWORK: Computer connection through Ethernet protocol. Two 8-pin RJ45 / EtherCon® compatible connectors with an internal switch allow the connection of several units in daisy-chain. Please refer to Master Audio DSPStudio Quick Installation Guide for more information on the remote connection.

H) BALANCED INPUT/LINK:

XLR-3 Female balanced signal connector for signal input.

XLR-3 Male connector for parallel connection of various cabinets with the same input signal.

IMPORTANT: Please always use balanced microphone cable with the following pin assignment:

1= Shield (Ground) 2= Live (+) 3= Return (-)

I) AC INPUT/OVERVOLTAGE PROTECTION: These leds show the status of the AC mains supply.

- **ON:** (Blue) When lit, the equipment is ON and the AC input level is within the permitted range (200 to 260 VAC).
- **STANDBY:** (Orange) This led is lit when the equipment is sensing the AC voltage at the input. At power-up this led will lit for a second while the systems checks for the input voltage.
- **OVERVOLTAGE:** (Red) If activated, the AC voltage is out of the permitted range of the equipment (>260VAC). The equipment will not power up until this

condition is solved. Revise your connections and mains power installation and consider that other equipment connected to this line may have been damaged.

J) AC MAINS INPUT/LINK: Mains supply connection via PowerCon.

- Blue connector for AC in.
- Grey connector to feed other units in parallel. Linking up to 4 units of X210A is possible, provided that a quality cable of a minimum section of 3x2,5mm² is used. Connecting more than 4 units in parallel may lead to a voltage drop in the cable that will reduce the equipment performance.



Always use mains power cable supplied by manufacturer.
Never connect the Xcellence Line Array cabinets to an unearthed mains supply or by using an unearthed mains cable.

2.4. Dimensions

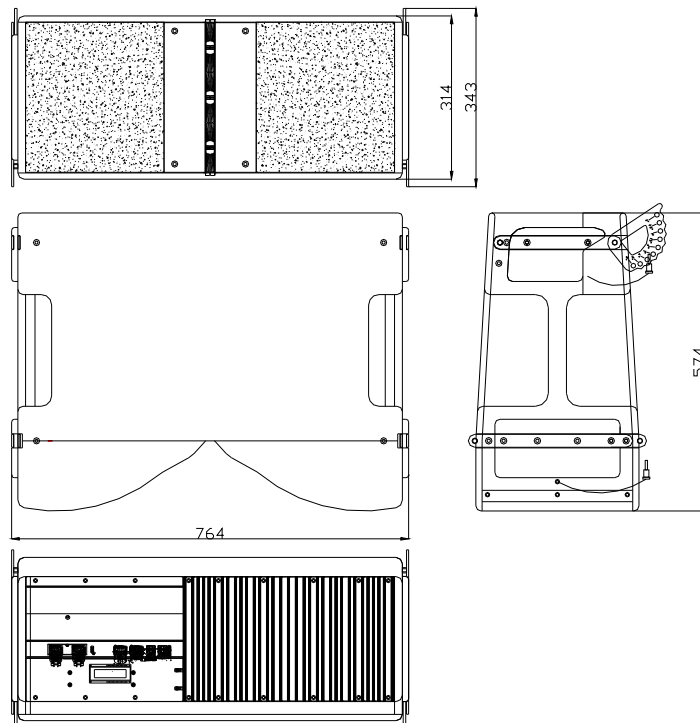

Fig.10. X210 cabinet. External dimensions

3. X215W SUBWOOFER

The X215W cabinet is ideal for bass reinforcement in general and specifically in combination with the model X210. It includes 2400W amplification for the woofers and digital signal control by DSP. The manufacturer presets (LPF90+3, LPF90+6, LPF100+3, LPF100+6, LPF110+3, LPF110+6, LPF120+3, LPF120+6, CARDIOID) make it easy, flexible and user-friendly.

The 15" neodymium woofers used, thanks to their exclusive magnetic design, combine excellent bass frequency response, high performance and low distortion. These features are mainly due to the presence of demodulation rings which drastically reduce the inter-modulation and third order distortion and considerably improve the transitory response. There is excellent heat dissipation due to the

external positioning of the magnet set. Without any doubt one of the finest bass transducers currently available.

The result is a clean, high quality sound.

3.1. Technical description

The X215W cabinet comes with DSP control, with acoustic bandpass cabinet. As a bass reinforcement system, its usable bandwidth is 32Hz-130Hz (-10dB).

It has 2400W continuous amplification, thermal protection, short circuit protection at the output, maximum power limiter, and protection against overvoltage. The DSP includes some presets which can be selected either accessing the cabinet's rear control panel or via the computer with Ethernet connection. The LPF90+3 preset means low pass filter at 90Hz and +3dB boost at 50Hz; LPF90+6 means low pass filter at 90Hz and +6dB boost at 50Hz; LPF100+3 means low pass filter at 100Hz and +3dB boost at 50Hz; LPF100+6 means low pass filter at 100Hz and +6dB boost at 50Hz; LPF110+3 means low pass filter at 110Hz and +3dB boost at 50Hz; LPF110+6 means low pass filter at 110Hz and +6dB boost at 50Hz; LPF120+3 means low pass filter at 120Hz and +3dB boost at 50Hz; LPF120+6 means low pass filter at 120Hz and +6dB boost at 50Hz and CARDIOID means cardioid polar pattern when used in combination with two other X215W subwoofers.

The X215W is connected using the XLR balanced connectors. Mains supply is through PowerCon at 230V.

High resistance weatherproof bi-component paint. The front face is protected by two 1.5 mm thick steel grilles with acoustically transparent grey cloth.

It includes in-built black painted stainless steel rigging hardware and handles for an easy and comfortable transport.

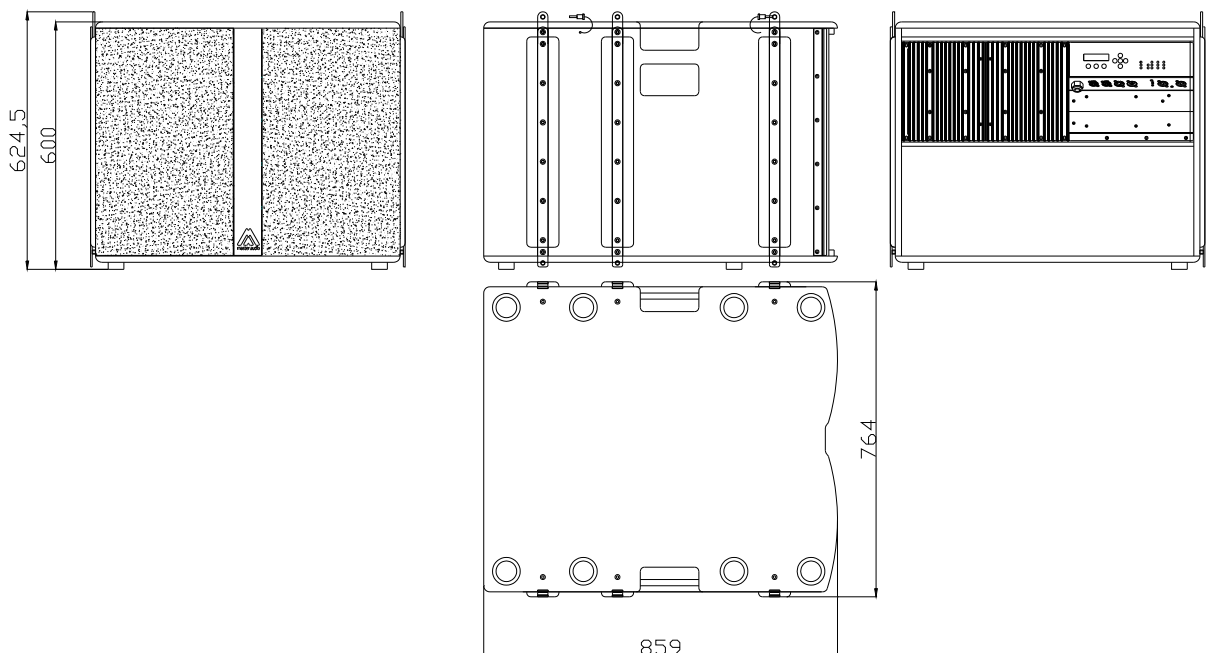

Fig.11. X215W cabinet. External dimensions

3.2. Presets

The X215W includes some manufacturer presets for different types of application. The DSP system can also store up to 23 customer's presets, depending on user requirements.

P1-LPF90+3

90Hz
low pass filter
with +3dB boost
at 50Hz

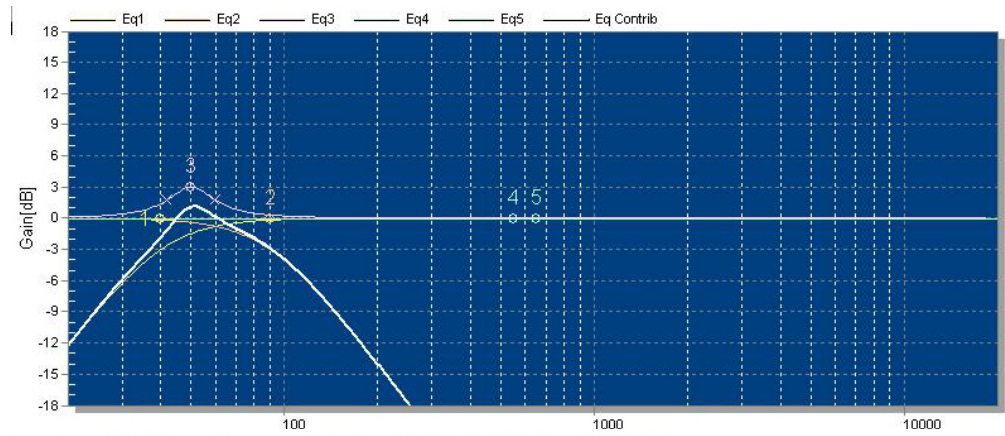

P2-LPF90+6

90Hz
low pass filter
with +6dB boost
at 50Hz

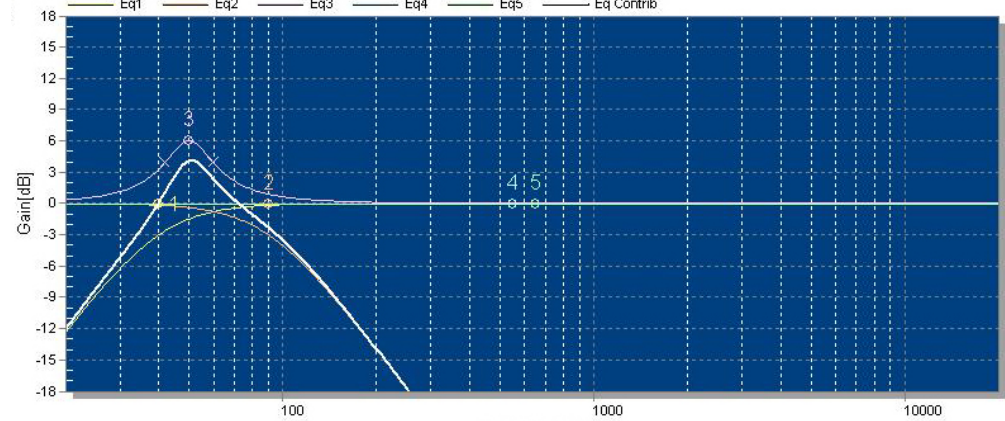

P3-LPF100+3

100Hz
low pass filter
with +3dB boost
at 50Hz

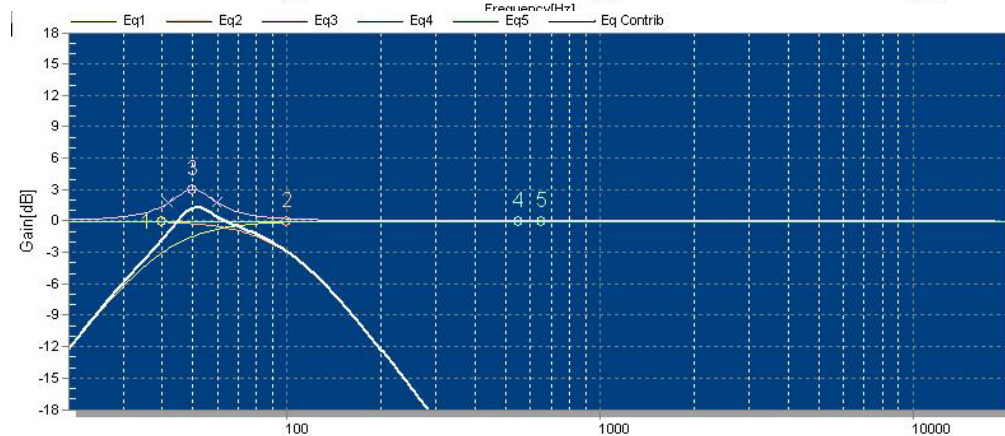

P4-LPF100+6

100Hz
low pass filter
with +6dB boost
at 50Hz

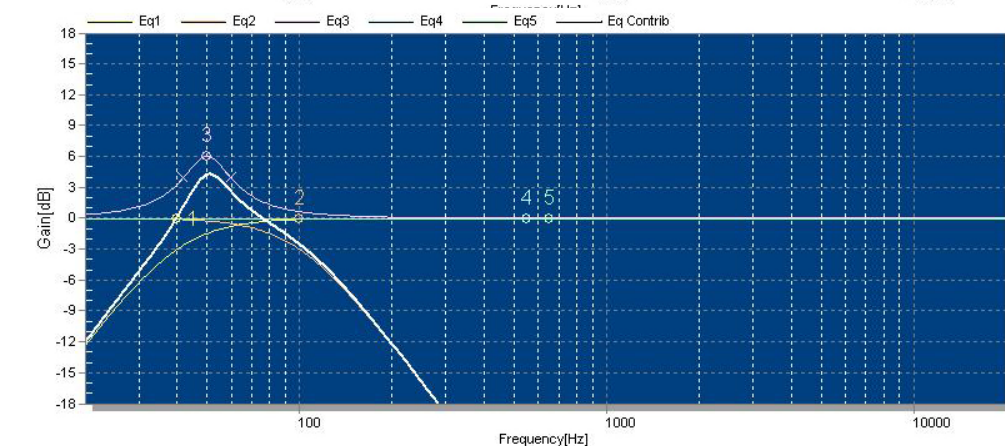

P5-LPF110+3

110Hz
low pass filter
with +3dB boost
at 50Hz

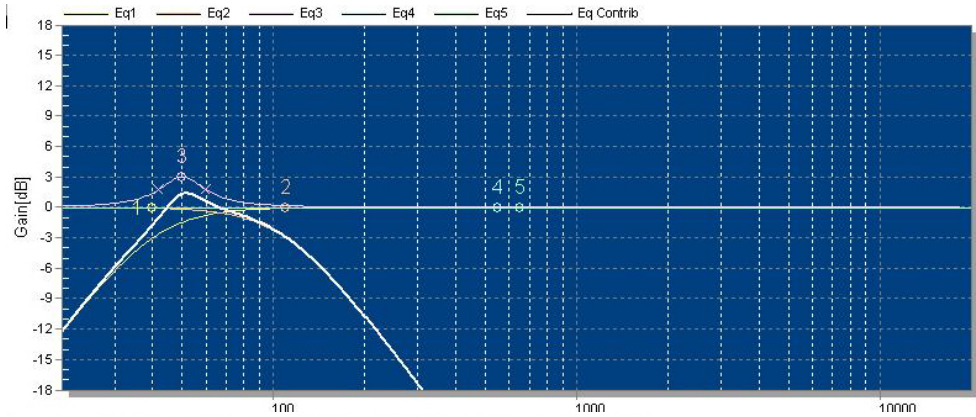

P6-LPF110+6

110Hz
low pass filter
with +6dB boost
at 50Hz

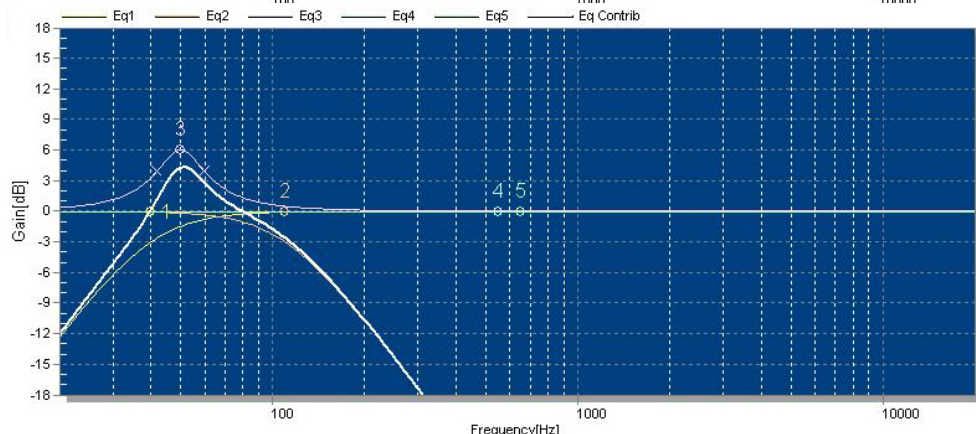

P7-LPF120+3

120Hz
low pass filter
with +3dB boost
at 50Hz

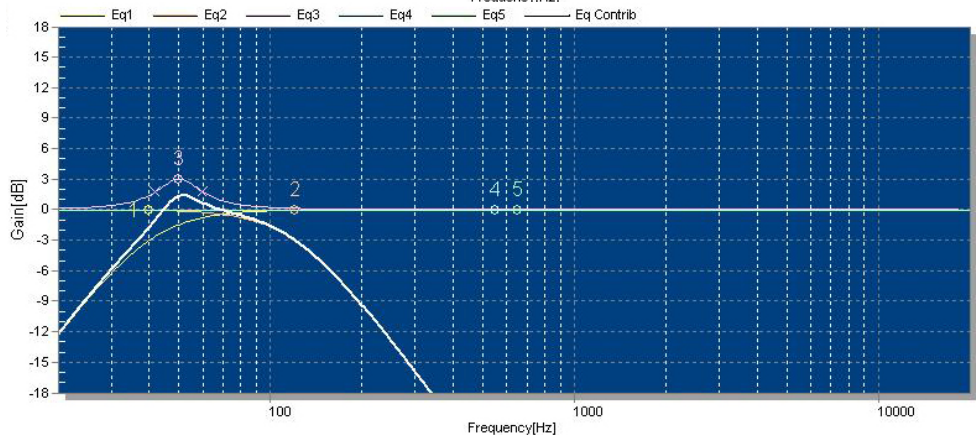

P8-LPF120+6

120Hz
low pass filter
with +6dB boost
at 50Hz

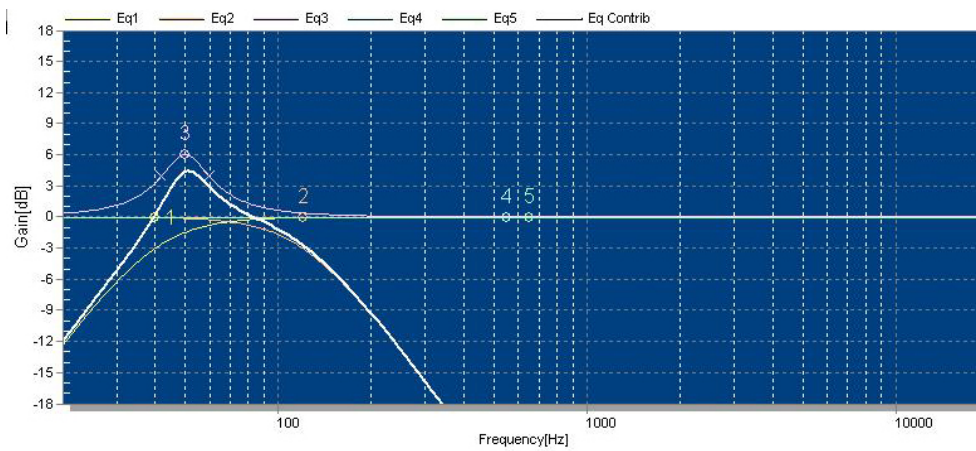

P9-CARDIOID

(Cardioid polar pattern)

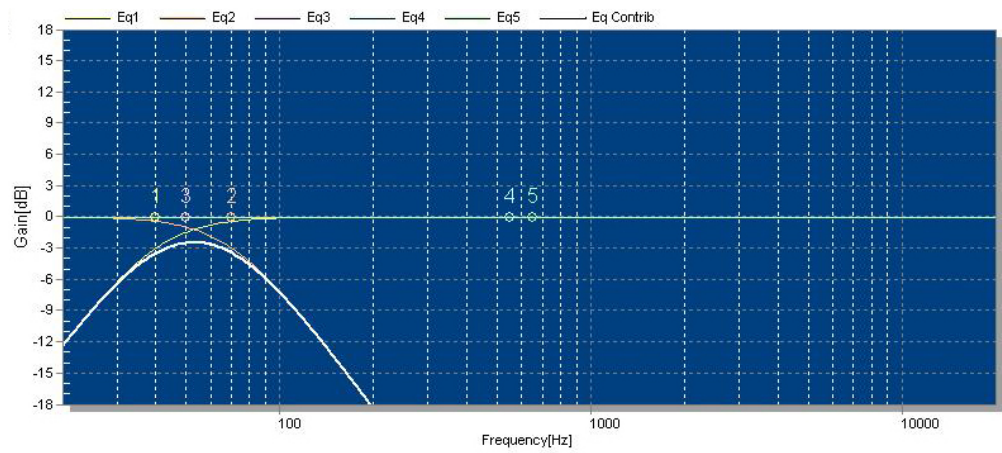

Fig.12. X215W PRESET options

3.3. Control and connection panel

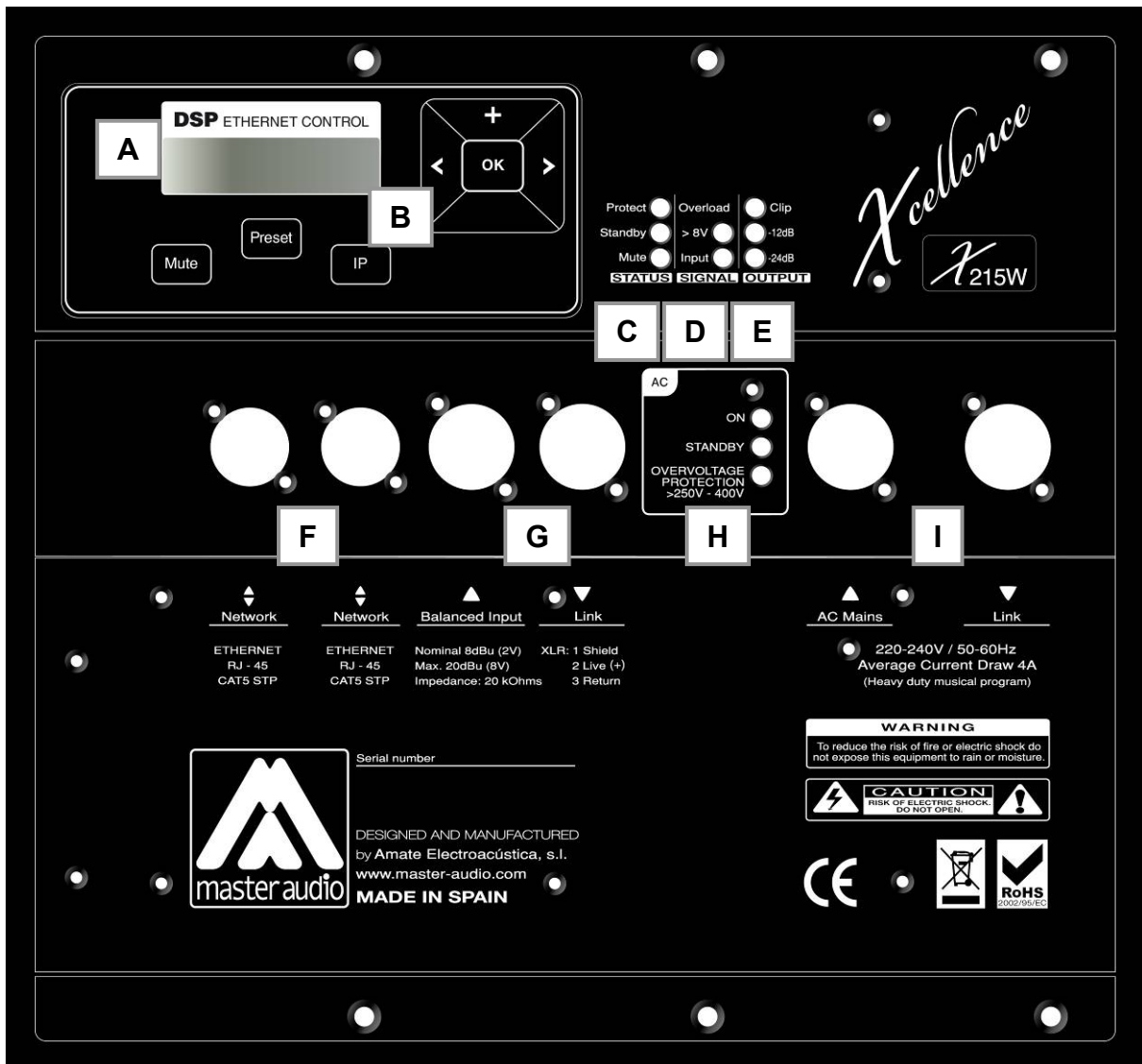

Fig.13. X215W control and connection panel

The X215W control panel contains the following elements:

A) LCD: Displays basic information about the DSP Status

B) KEYPAD: Allows the user to perform basic operations on the DSP such as IP address setting, Preset selection, etc.

C) STATUS LEDES: Report a special event happening in the system

- **Protect:** (Red) A fault condition is being reported by the amplifier. If this LED is constantly lit even after resetting the device, please contact the technical service.
- **Standby:** (Orange) This led is lit when the equipment is set in Low Power Consumption mode. This mode can only be set through the PC connection.
- **Mute:** (Orange) The system is muted (amplifiers are disabled). The system can be muted from the PC remote control or from the keypad.

IMPORTANT: When the amplifier is in MUTE, the PROTECT LED will be also lit to show that the amplifier is disabled. Also when the system is waking up from the STANDBY mode, the PROTECT led will be lit for a few seconds. Under these circumstances the PROTECT LED is reporting that the amplifier is disabled, but not a fault condition.

D) SIGNAL INPUT LEDES: Monitor the signal arriving at the module input.

- **Input:** Signal is present at the input. Nominal input level is +8dBu (2Vrms).
- **OVLD:** The input signal exceeds +14dBu (4Vrms), so it will be compressed. Avoid the continuous lighting of this led in order to preserve the dynamic range of the audio signal.

E) OUPUT LEDES: Show the amplifier output level

- **-24dB:** The amplifier is delivering output power at -24dB of its maximum power
- **-12dB:** The amplifier is delivering output power at -12dB of its maximum power
- **Clip:** The amplifier is delivering its maximum output power

The connection panel has the following parts:

F) NETWORK: Computer connection through Ethernet protocol. Two 8-pin RJ45 / EtherCon® compatible connectors with an internal switch allow the connection of several units in daisy-chain. Please refer to Master Audio DSPStudio Quick Installation Guide for more information on the remote connection.

G) BALANCED INPUT/LINK:

XLR-3 Female balanced signal connector for signal input.

XLR-3 Male connector for parallel connection of various cabinets with the same input signal.

IMPORTANT: Please always use balanced microphone cable with the following pin assignment:

1= Shield (Ground) 2= Live (+) 3= Return (-)

H) AC INPUT/OVERVOLTAGE PROTECTION: These leds show the status of the AC mains supply.

- **ON:** (Blue) When lit, the equipment is ON and the AC input level is within the permitted range (200 to 260 VAC).
- **STANDBY:** (Orange) This led is lit when the equipment is sensing the AC voltage at the input. At power-up this led will lit for a second while the systems checks for the input voltage.
- **OVERVOLTAGE:** (Red) If activated, the AC voltage is out of the permitted range of the equipment (>260VAC). The equipment will not power up until this condition is solved. Revise your connections and mains power installation and consider that other equipment connected to this line may have been damaged.

I) AC MAINS INPUT/LINK: Mains supply connection via PowerCon.

- Blue connector for AC in.
- Grey connector to feed other units in parallel. Linking up to 2 units of X215W is possible, provided that a quality cable of a minimum section of 3x2,5mm² is used. Connecting more than 2 units in parallel may lead to a voltage drop in the cable that will reduce the equipment performance.

4. X218W SUBWOOFER

The X218W cabinet is ideal for bass reinforcement in general and matches perfectly in combination with the model X210. It includes 2400W amplification for the woofers and digital signal control by DSP. The manufacturer presets (LPF90, LPF90+3, LPF110, LPF110+3, LPF80, LPF80+3, CARDIOID) make it easy, flexible and user-friendly.

The 18" neodymium woofers used, thanks to their exclusive magnetic design, combine excellent bass frequency response, high performance and low distortion. These features are mainly due to the presence of demodulation rings which drastically reduce the inter-modulation and third order distortion and considerably improve the transitory response. There is excellent heat dissipation due to the external positioning of the magnet set. Without any doubt one of the finest bass transducers currently available. The result is a clean, high quality sound.

4.1. Technical description

The X218W cabinet comes with DSP control, with acoustic bass-reflex cabinet. As a bass reinforcement system, its usable bandwidth is 30Hz-120Hz (-10dB).

It has 2400W continuous amplification, thermal protection, anti-short circuit protection at the output, maximum power limiter, and protection against overvoltage. The DSP includes some presets which can be selected either accessing the cabinet's rear control panel or via the computer with Ethernet connection. The LPF90 preset means low pass filter at 90Hz; LPF90+3 means low pass filter at 90Hz with +3dB boost at 42Hz; LPF110 means low pass filter at 110Hz, LPF110+3 means low pass filter at 110Hz with +3dB boost at 42Hz, LPF80 preset means low pass filter at 80Hz; LPF80+3 means low pass filter at 80Hz with +3dB boost at 42Hz and CARDIOID means cardioid polar pattern when used in combination with two other X218W subwoofers. The X218W is connected using the XLR balanced connectors. Mains supply is through PowerCon at 230V.

Built in birch plywood, which has a high resistance to vibrations and humidity. High resistance weatherproof bi-component paint. The front face is protected by two 1.5 mm thick steel grille with acoustically transparent grey cloth.

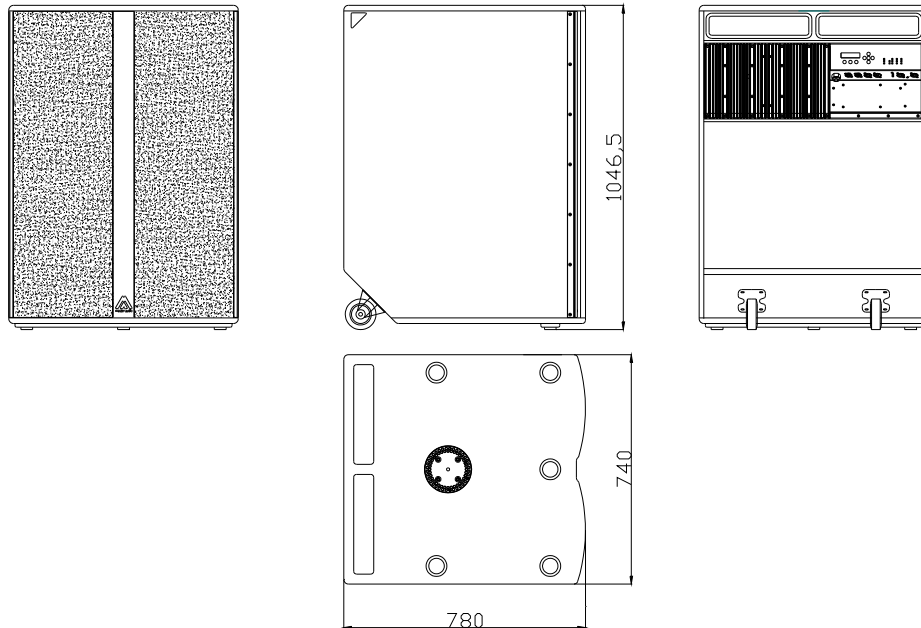

Fig.14. X218W cabinet. External dimensions

4.2. Presets

The X218W includes some manufacturer presets for different types of application. The DSP system can also store up to 23 customer's presets, depending on user requirements.

P1-LPF90

90Hz
low pass filter

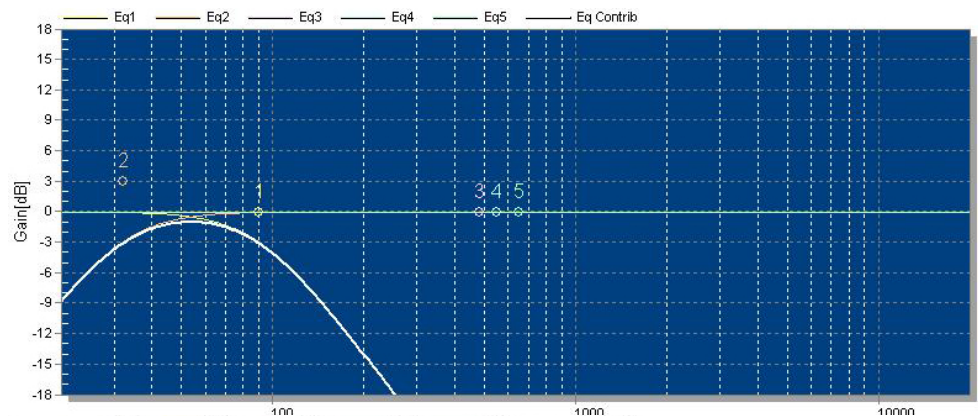

P2-LPF90+3

90Hz
low pass filter,
+3dB boost
at 42Hz

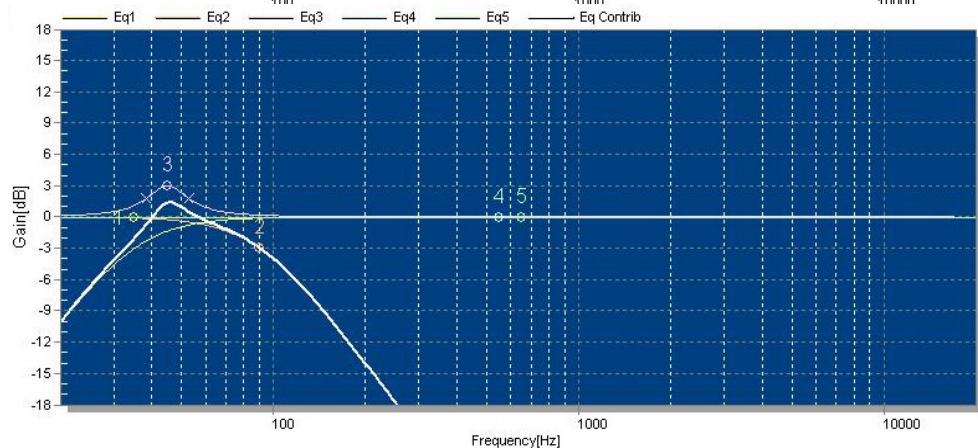

P3-LPF110

110Hz
low pass filter

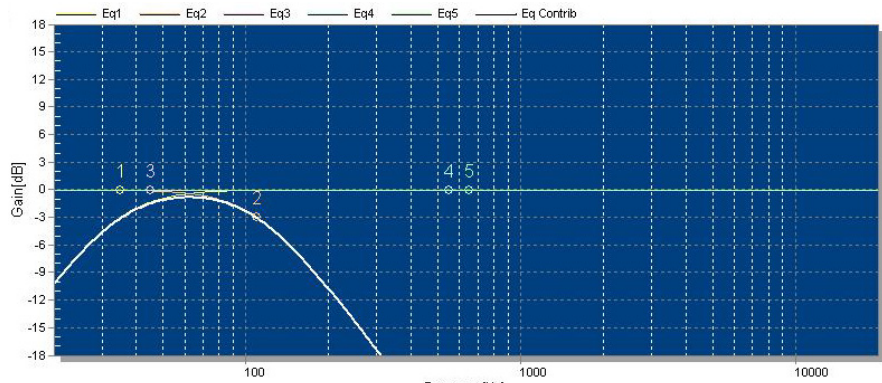

P4-LPF110+3

110Hz
low pass filter,
+3dB boost
at 42Hz

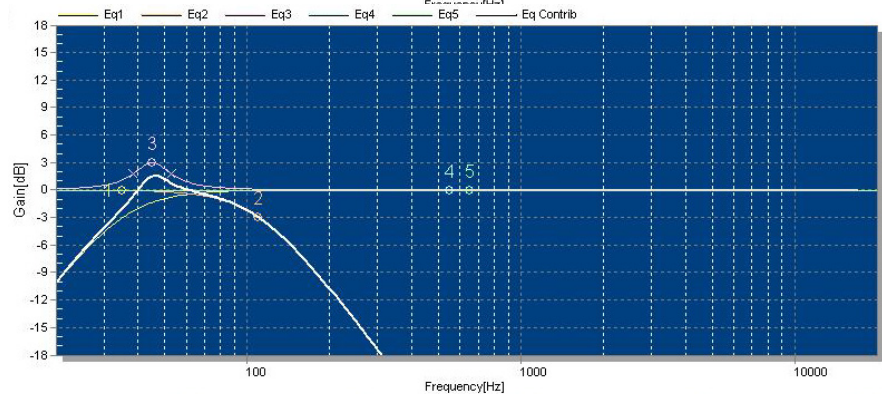

P5-CARDIOID

(Cardioid
polar pattern)

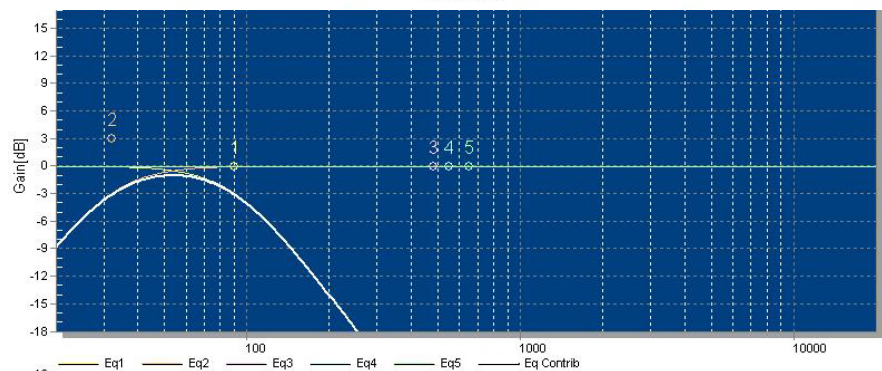

P6-LPF80

80Hz
low pass filter

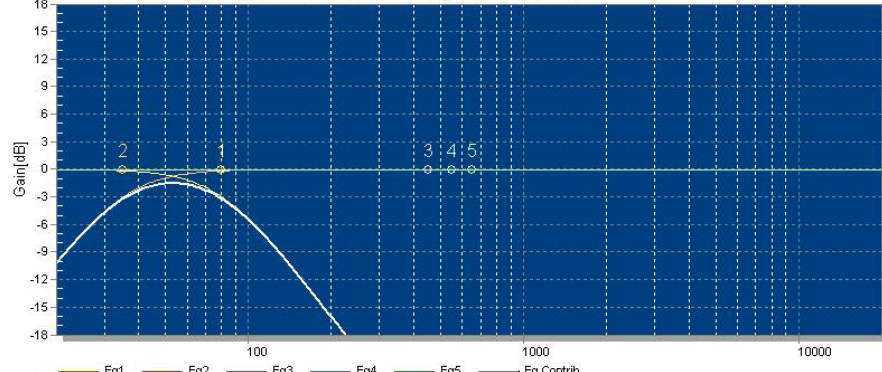

P7-LPF80+3

80Hz
low pass filter,
+3dB boost
at 42Hz

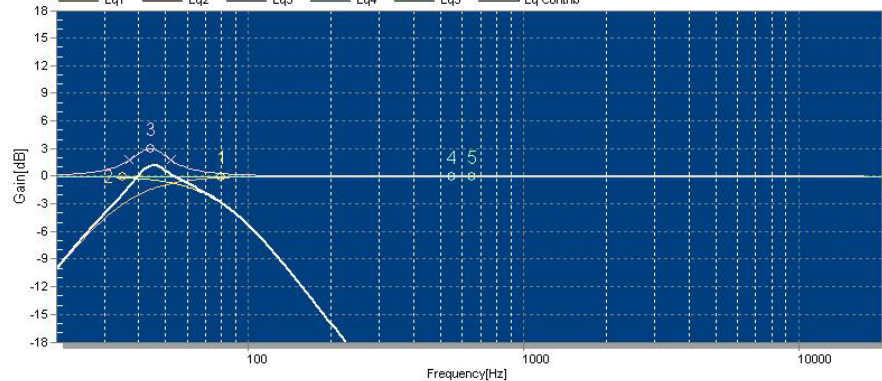

Fig.15. X218W PRESET options

4.3. Control and connection Panel

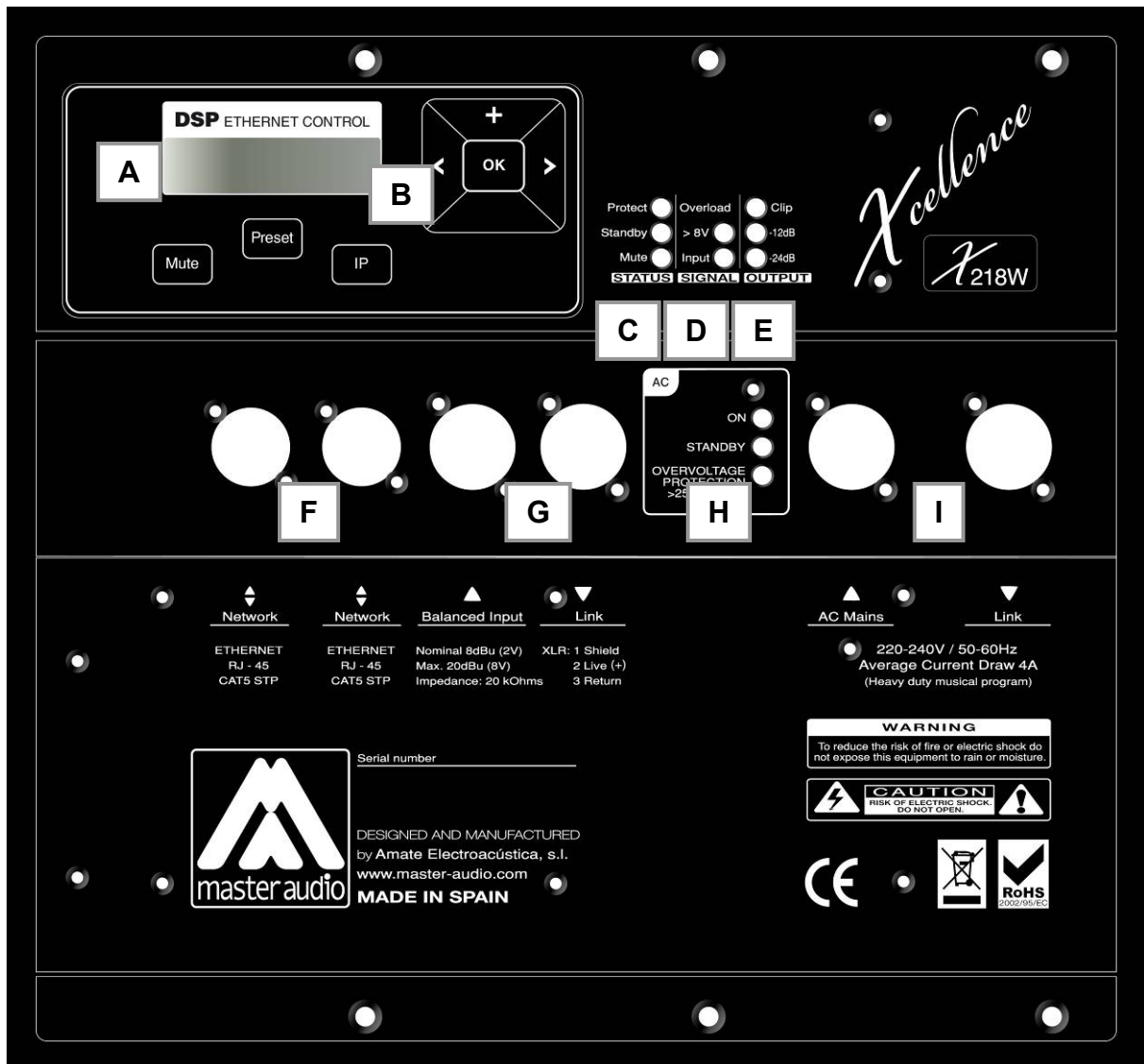

Fig.16. X218W connection panel

The X218W control panel contains the following elements:

A) LCD: Displays basic information about the DSP Status

B) KEYPAD: Allows the user to perform basic operations on the DSP such as IP address setting, Preset selection, etc.

C) STATUS LEDs: Report a special event happening in the system

- **Protect:** (Red) A fault condition is being reported by the amplifier. If this LED is constantly lit even after resetting the device, please contact the technical service.
- **Standby:** (Orange) This led is lit when the equipment is set in Low Power Consumption mode. This mode can only be set through the PC connection.
- **Mute:** (Orange) The system is muted (amplifiers are disabled). The system can be muted from the PC remote control or from the keypad.

IMPORTANT: When the amplifier is in MUTE, the PROTECT LED will be also lit to show that the amplifier is disabled. Also when the system is waking up from the STANDBY mode, the PROTECT led will be lit for a few seconds. Under these circumstances the PROTECT LED is reporting that the amplifier is disabled, but not a fault condition.

D) SIGNAL INPUT LEDS: Monitor the signal arriving at the module input.

- **Input:** Signal is present at the input. Nominal input level is +8dBu (2Vrms).
- **OVL D:** The input signal exceeds +14dBu (4Vrms), so it will be compressed. Avoid the continuous lighting of this led in order to preserve the dynamic range of the audio signal.

E) OUPUT LEDS: Show the amplifier output level

- **-24dB:** The amplifier is delivering output power at -24dB of its maximum power
- **-12dB:** The amplifier is delivering output power at -12dB of its maximum power
- **Clip:** The amplifier is delivering its maximum output power

The connection panel has the following parts:

F) NETWORK: Computer connection through Ethernet protocol. Two 8-pin RJ45 / EtherCon® compatible connectors with an internal switch allow the connection of several units in daisy-chain. Please refer to Master Audio DSPStudio Quick Installation Guide for more information on the remote connection.

G) BALANCED INPUT/LINK:

XLR-3 Female balanced signal connector for signal input.

XLR-3 Male connector for parallel connection of various cabinets with the same input signal.

IMPORTANT: Please always use balanced microphone cable with the following pin assignment:

1= Shield (Ground) 2= Live (+) 3= Return (-)

H) AC INPUT/OVERVOLTAGE PROTECTION: These leds show the status of the AC mains supply.

- **ON:** (Blue) When lit, the equipment is ON and the AC input level is within the permitted range (200 to 260 VAC).
- **STANDBY:** (Orange) This led is lit when the equipment is sensing the AC voltage at the input. At power-up this led will lit for a second while the systems checks for the input voltage.
- **OVERVOLTAGE:** (Red) If activated, the AC voltage is out of the permitted range of the equipment (>260VAC). The equipment will not power up until this condition is solved. Revise your connections and mains power installation and consider that other equipment connected to this line may have been damaged.

I) AC MAINS INPUT/LINK: Mains supply connection via PowerCon.

- Blue connector for AC in.
- Grey connector to feed other units in parallel. Linking up to 2 units of X218W is possible, provided that a quality cable of a minimum section of 3x2,5mm² is used. Connecting more than 2 units in parallel may lead to a voltage drop in the cable that will reduce the equipment performance.

5. X218W3K SUBWOOFER

The X218W3K cabinet is ideal for bass reinforcement in general and matches perfectly in combination with the model X210. It includes 3000W amplification for the woofers and digital signal control by DSP. The manufacturer presets (LPF90, LPF90+3, LPF100, LPF100+3, LPF110, LPF110+3, LPF80, LPF80+3, CARD90, CARD100, CARD110) make it easy, flexible and user-friendly.

The 18" neodymium woofers used, thanks to their exclusive magnetic design, combine excellent bass frequency response, high performance and low distortion. These features are mainly due to the presence of demodulation rings which drastically reduce the inter-modulation and third order distortion and considerably improve the transitory response. There is excellent heat dissipation due to the external positioning of the magnet set. Without any doubt one of the finest bass transducers currently available. The result is a clean, high quality sound.

5.1. Technical description

The X218W3K cabinet comes with DSP control, with acoustic bass-reflex cabinet. As a bass reinforcement system, its usable bandwidth is 28Hz-120Hz (-10dB). It has 3000W continuous amplification, thermal protection, anti-short circuit protection at the output, maximum power limiter, and protection against overvoltage. The DSP includes some presets which can be selected either accessing the cabinet's rear control panel or via the computer with Ethernet connection. The LPF90 preset means low pass filter at 90Hz; LPF90+3 means low pass filter at 90Hz with +3dB boost at 44Hz; ; LPF100 means low pass filter at 100Hz, LPF100+3 means low pass filter at 100Hz with +3dB boost at 44Hz; LPF110 means low pass filter at 110Hz, LPF110+3 means low pass filter at 110Hz with +3dB boost at 44Hz, LPF80 preset means low pass filter at 80Hz; LPF80+3 means low pass filter at 80Hz with +3dB boost at 44Hz and CARD90/100/110 means cardioid polar pattern when used in combination with two other X218W3K subwoofers. The X218W3K is connected using the XLR balanced connectors. Mains supply is through PowerCon at 230V.

Built in birch plywood, which has a high resistance to vibrations and humidity. High resistance weatherproof bi-component Polyurea paint. The front face is protected by two 1.5 mm thick steel grille with acoustically transparent grey cloth.

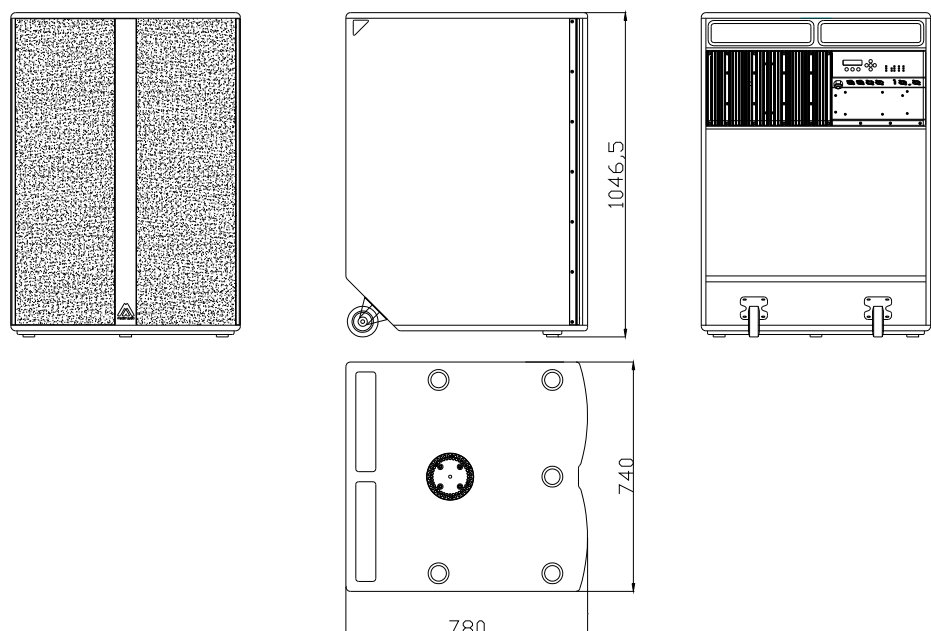

Fig.17. X218W3K cabinet. External dimensions

5.2. Presets

The X218W3K includes some manufacturer presets for different types of application. The DSP system can also store up to 23 customer's presets, depending on user requirements.

P1-LPF90

90Hz
low pass filter

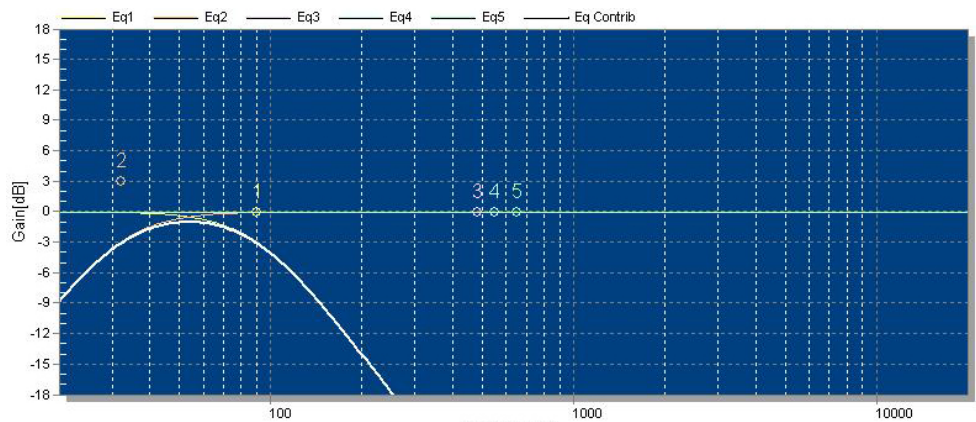

P2-LPF90+3

90Hz
low pass filter,
+3dB boost
at 44Hz

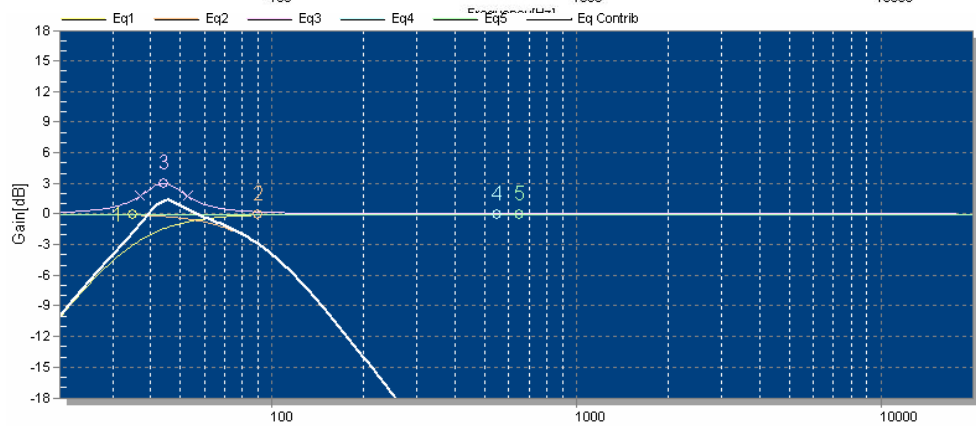

P3-LPF100

100Hz
low pass filter

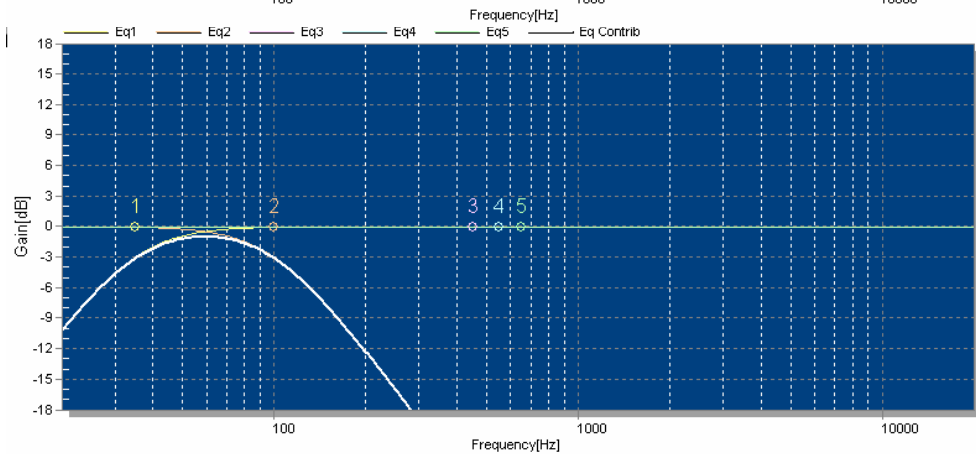

P4-LPF100+3

100Hz
low pass filter,
+3dB boost
at 44Hz

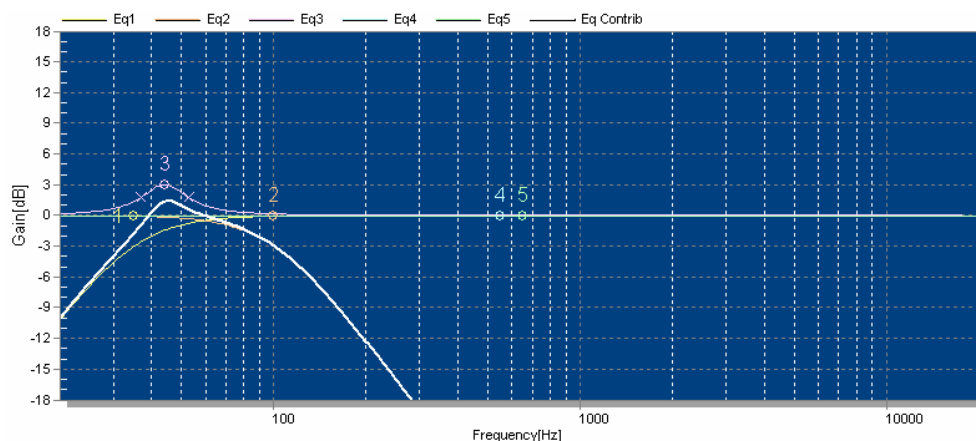

P5-LPF110

110Hz
low pass filter

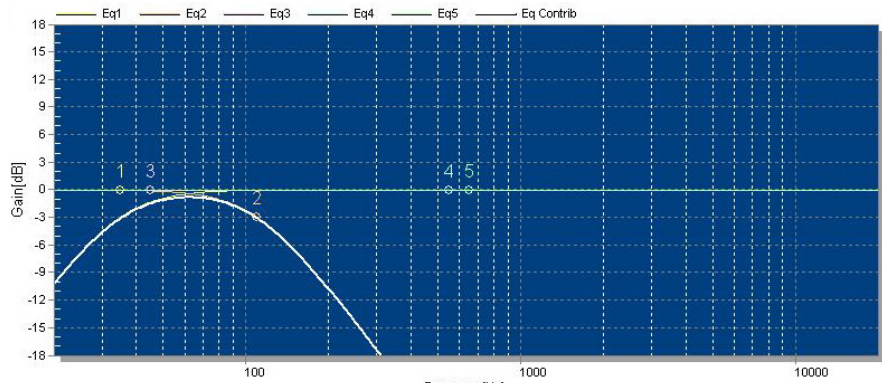

P6-LPF110+3

110Hz
low pass filter,
+3dB boost
at 44Hz

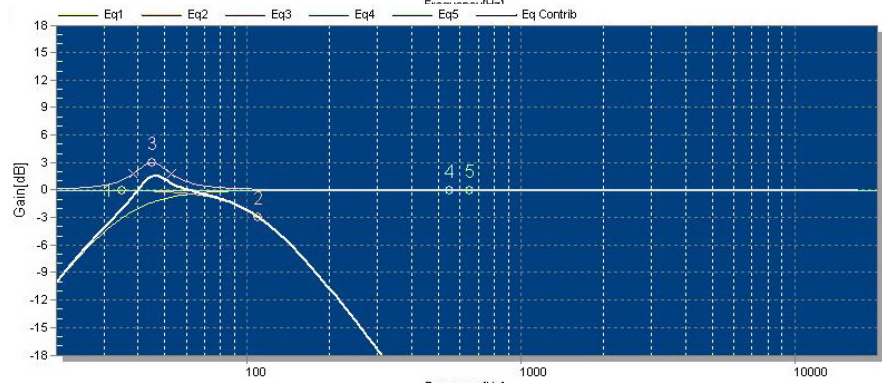

P7-LPF80

80Hz
low pass filter

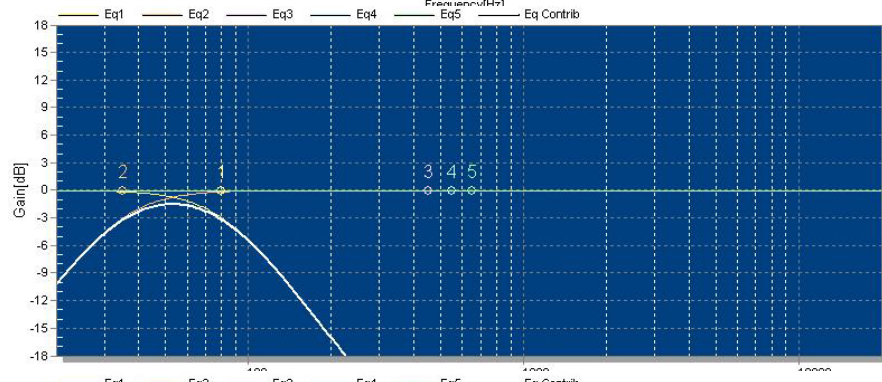

P8-LPF80+3

80Hz
low pass filter,
+3dB boost
at 44Hz

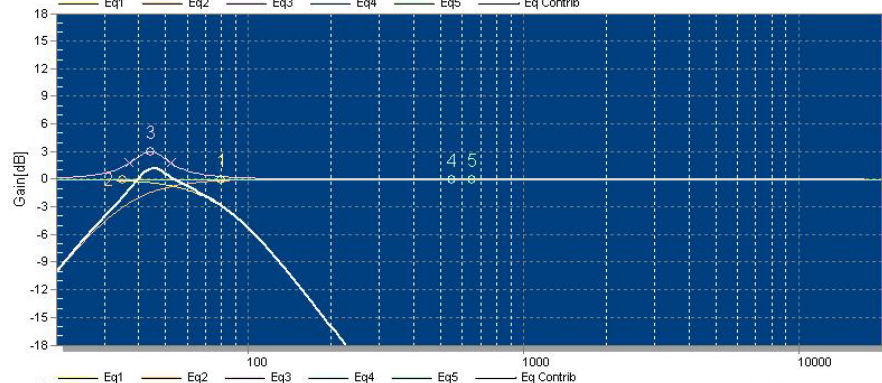

P9-CARD90

(Cardioid polar
pattern when
used with LPF90
preset)

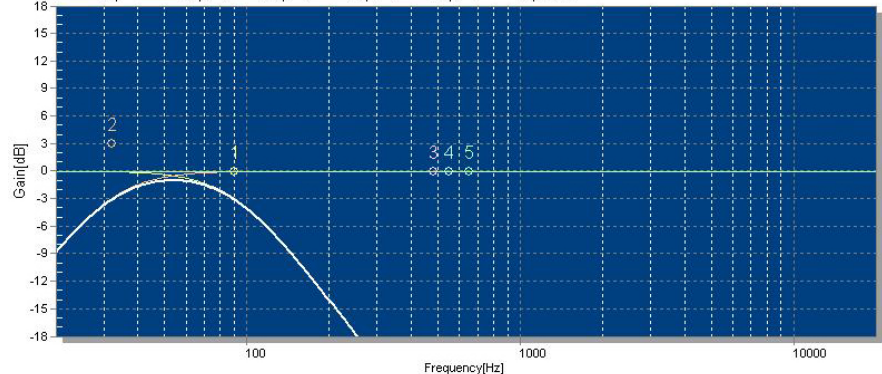

P10-CARD100

(Cardioid polar pattern when used with LPF100 preset)

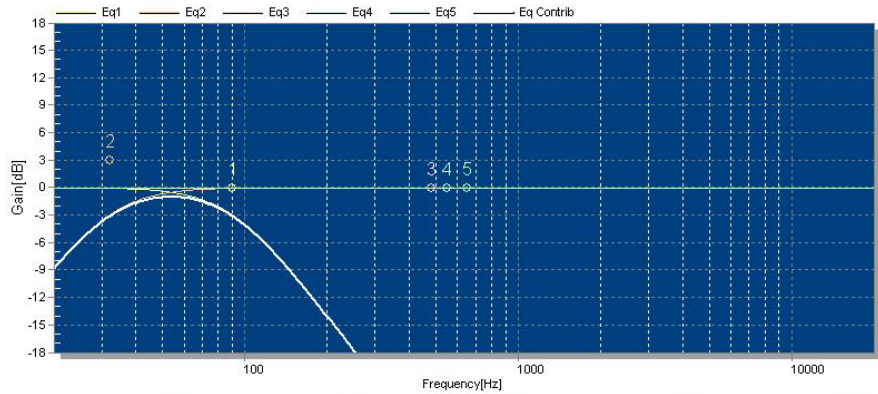

P11-CARD110

(Cardioid polar pattern when used with LPF110 preset)

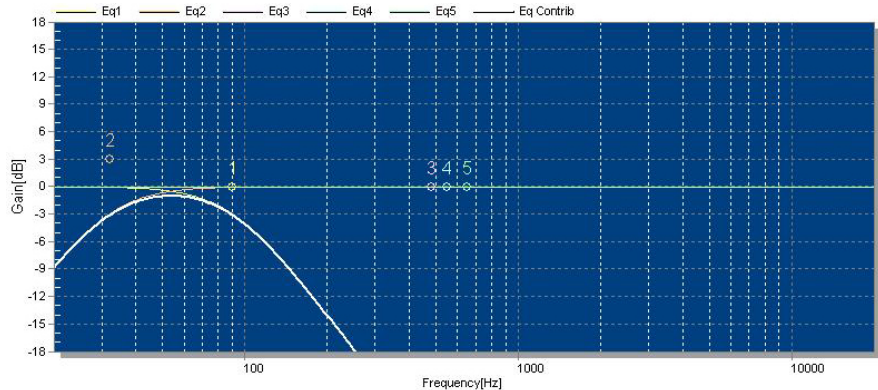

Fig.18. X218W3K PRESET options

5.3. Control and connection Panel

The X218W3K control panel contains the following elements:

- A) LCD:** Displays basic information about the DSP Status
- B) KEYPAD:** Allows the user to perform basic operations on the DSP such as IP address setting, Preset selection, etc.
- C) STATUS LEDs:** Report a special event happening in the system
 - **Protect:** (Red) A fault condition is being reported by the amplifier. If this LED is constantly lit even after resetting the device, please contact the technical service.
 - **Standby:** (Orange) This led is lit when the equipment is set in Low Power Consumption mode. This mode can only be set through the PC connection.
 - **Mute:** (Orange) The system is muted (amplifiers are disabled). The system can be muted from the PC remote control or from the keypad.

IMPORTANT: When the amplifier is in MUTE, the PROTECT LED will be also lit to show that the amplifier is disabled. Also when the system is waking up from the STANDBY mode, the PROTECT led will be lit for a few seconds. Under these circumstances the PROTECT LED is reporting that the amplifier is disabled, but not a fault condition.

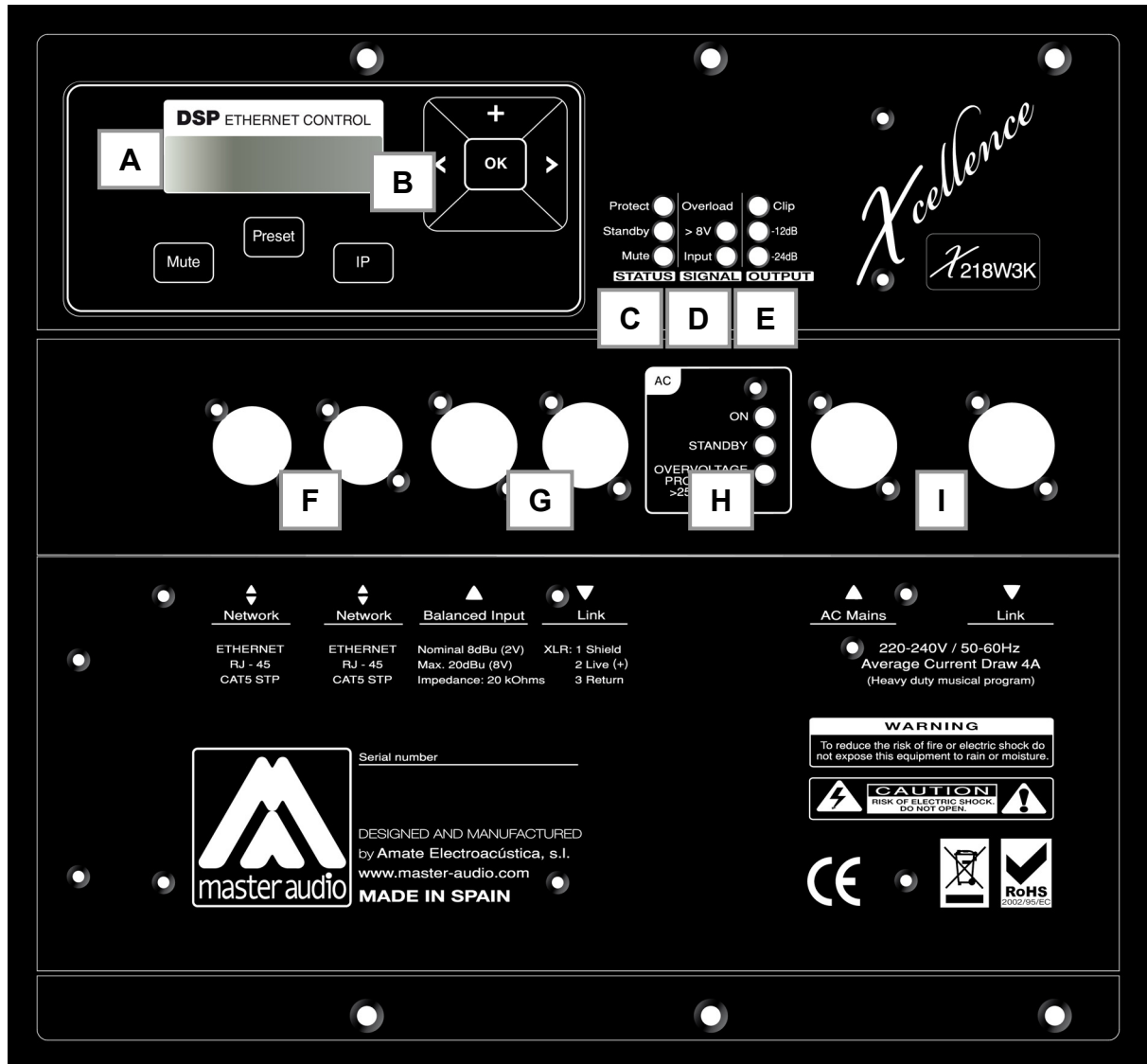

Fig.19. X218W3K connection panel

- D) SIGNAL INPUT LEDS:** Monitor the signal arriving at the module input.
- **Input:** Signal is present at the input. Nominal input level is +8dBu (2Vrms).
 - **OVLD:** The input signal exceeds +14dBu (4Vrms), so it will be compressed. Avoid the continuous lighting of this led in order to preserve the dynamic range of the audio signal.
- E) OUPUT LEDS:** Show the amplifier output level
- **-24dB:** The amplifier is delivering output power at -24dB of its maximum power
 - **-12dB:** The amplifier is delivering output power at -12dB of its maximum power
 - **Clip:** The amplifier is delivering its maximum output power

The connection panel has the following parts:

F) NETWORK: Computer connection through Ethernet protocol. Two 8-pin RJ45 / EtherCon® compatible connectors with an internal switch allow the connection of several units in daisy-chain. Please refer to Master Audio DSPStudio Quick Installation Guide for more information on the remote connection.

G) BALANCED INPUT/LINK:

XLR-3 Female balanced signal connector for signal input.

XLR-3 Male connector for parallel connection of various cabinets with the same input signal.

IMPORTANT: Please always use balanced microphone cable with the following pin assignment:

1= Shield (Ground) 2= Live (+) 3= Return (-)

H) AC INPUT/OVERVOLTAGE PROTECTION: These leds show the status of the AC mains supply.

- **ON:** (Blue) When lit, the equipment is ON and the AC input level is within the permitted range (200 to 260 VAC).
- **STANDBY:** (Orange) This led is lit when the equipment is sensing the AC voltage at the input. At power-up this led will lit for a second while the systems checks for the input voltage.
- **OVERVOLTAGE:** (Red) If activated, the AC voltage is out of the permitted range of the equipment (>260VAC). The equipment will not power up until this condition is solved. Revise your connections and mains power installation and consider that other equipment connected to this line may have been damaged.

I) AC MAINS INPUT/LINK: Mains supply connection via PowerCon.

- Blue connector for AC in.
- Grey connector to feed other units in parallel. Linking up to 2 units of X218W3K is possible, provided that a quality cable of a minimum section of 3x2,5mm² is used. Connecting more than 2 units in parallel may lead to a voltage drop in the cable that will reduce the equipment performance.

6. CARDIOID SUBWOOFERS

X215W, X218W and X218W3K enable the combination of three or multiple of three subwoofer cabinets in an array to provide exceptional directivity at low frequencies.

High directivity at low frequencies has two main effects on the sound field: firstly, the low frequency level behind the subwoofer cabinets is greatly reduced; secondly, in closed venues the diffuse sound field at low frequencies is reduced so the low frequency reproduction is much more precise.

The typical operating range of a traditional subwoofer tends to be like a monopole, i.e. tends to radiate with the same energy in all directions. This behaviour implies that the control of radiation at low frequencies is very difficult because the wavelengths are very large compared to the size of the source (8.5 m at 40Hz).

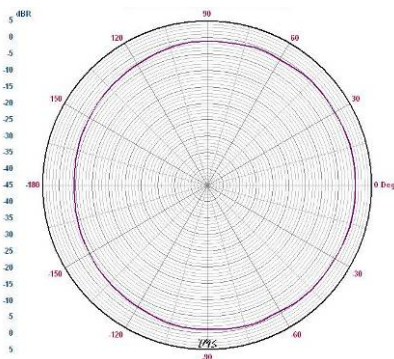
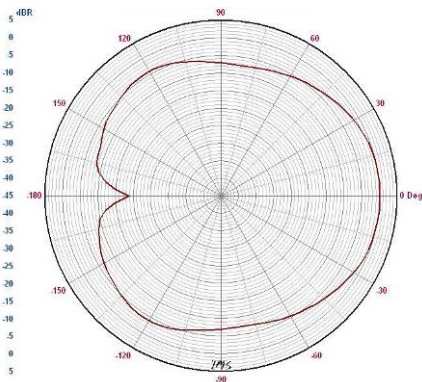

Fig.20. Traditional polar pattern of a subwoofer at 40Hz

To increase the directivity at low frequencies we must transform the omnidirectional performance into a cardioid performance. This can only be achieved by various sources, arranged in a certain position, to which we apply a specific phase, filtering and delay. That is, we need to reproduce two signals with the same frequency and similar amplitude which will have a difference in phase of approximately 180° at a certain point of the sound field.



If the phases and delays are well calculated the result is a system in which we cancel the energy of the back and not the one of the front.

This can only be achieved with cabinets that incorporate independent delay units on their DSP, as X215W, X218W, X218W3K.

Fig.21. Cardioid pattern

6.1. The CARDIOID preset

X215W, X218W, X218W3K can generate an uncompromised cardioid behaviour, which means that there is no need for special cabinets, enabling the use of the system's full efficiency with just "one finger".

In its minimum configuration a Cardioid setup consists of a stack of three subwoofer cabinets (for X215W) and of a horizontal line of three subwoofer cabinets (for X218W, X218W3K).

Only one subwoofer is needed to compensate for the energy of the other two radiating to the front. Then, the cabinet facing to the back (to the stage) should be located in the centre of the column.

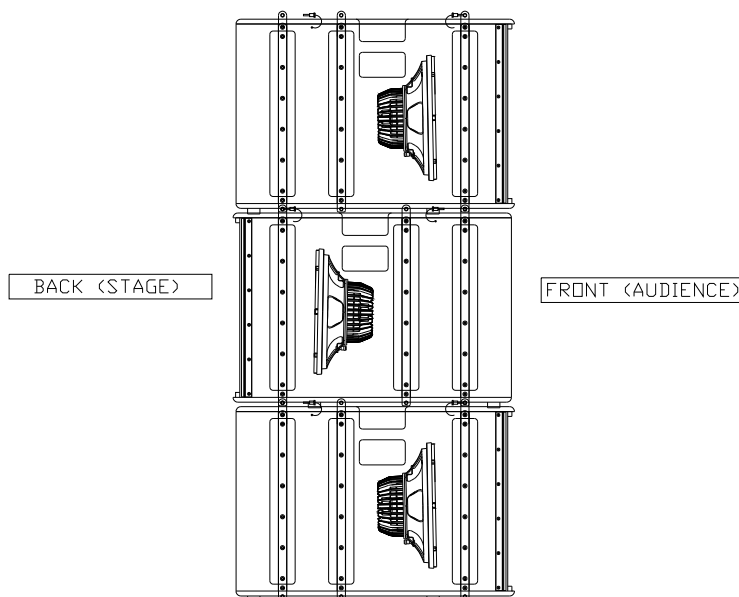

Fig.22. Cardioid configuration for X215W subwoofer

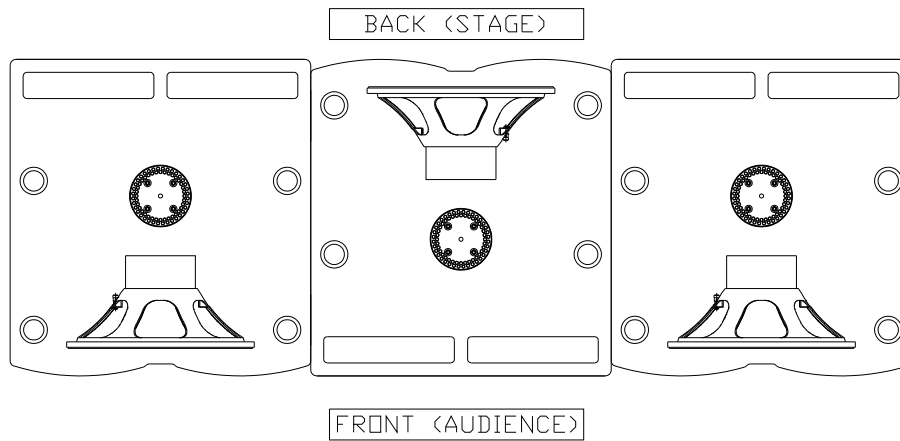
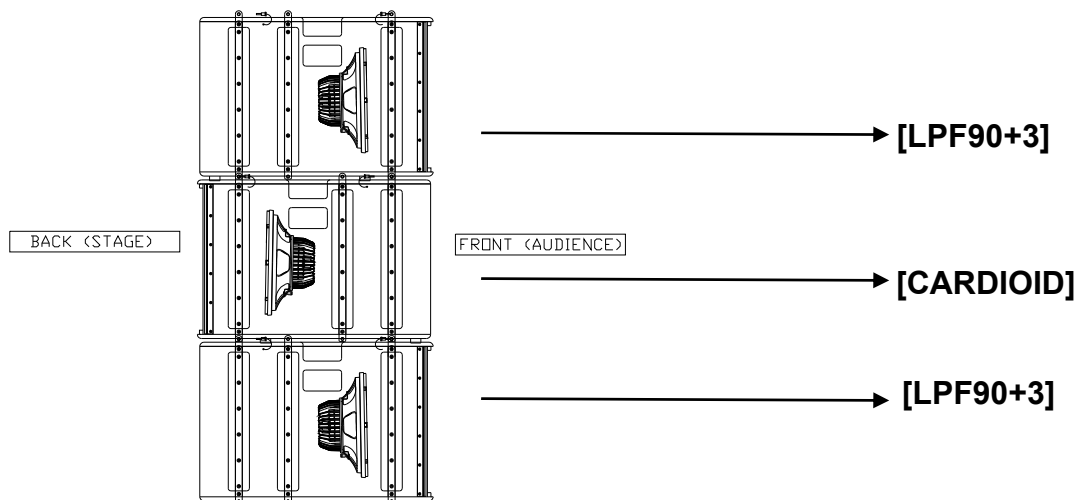

Fig.23. Cardioid configuration for X218W/X218W3K subwoofer

The front facing subwoofers must be driven with [LPF90+3] preset in X215W and [LPF90] preset in X218W and the back facing subwoofers must be driven with [CARDIOID] preset.

When using X218W3K choose one of the following options:

- a) The front facing subwoofers must be driven with [LPF90] preset and the back facing subwoofer must be driven with [CARD90] preset.
- or
- b) The front facing subwoofers must be driven with [LPF100] preset and the back facing subwoofer must be driven with [CARD100] preset.
- or
- c) The front facing subwoofers must be driven with [LPF110] preset and the back facing subwoofer must be driven with [CARD110] preset.



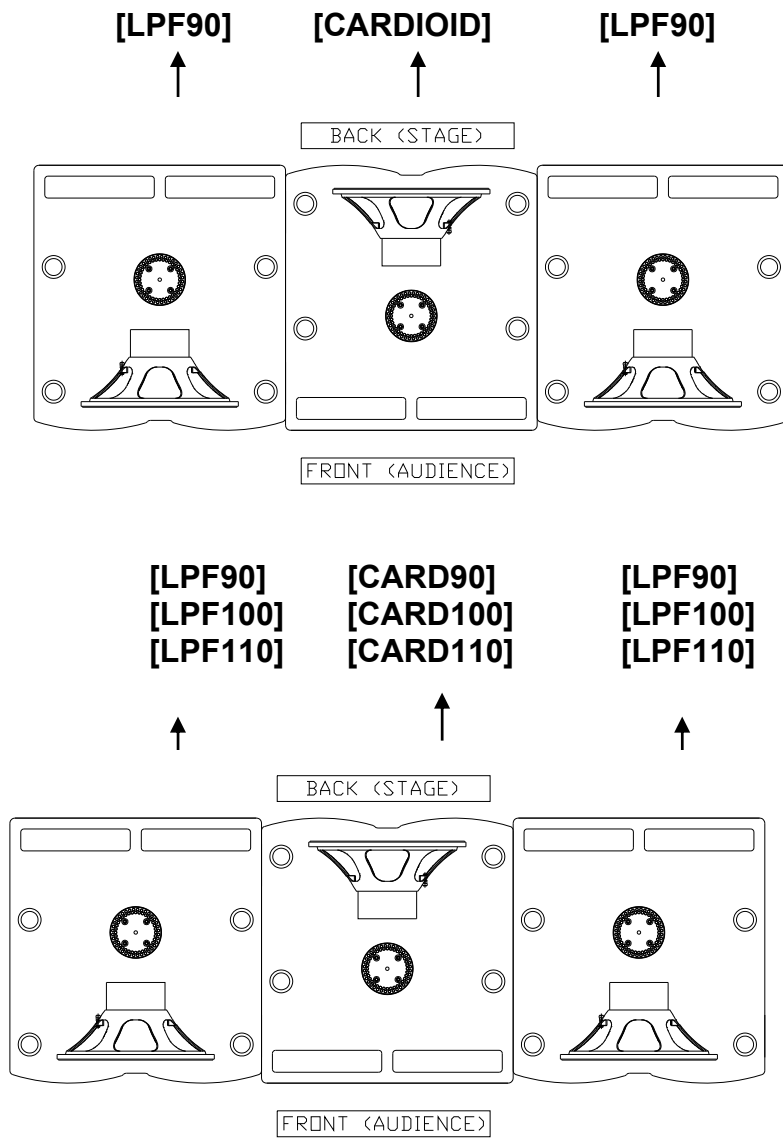

Fig.24. Presets for cardioid configuration

When placing the subwoofers in a cardioid configuration keep a distance to walls of at least 60 cm in order not to affect the radiation of the central reversed cabinet.

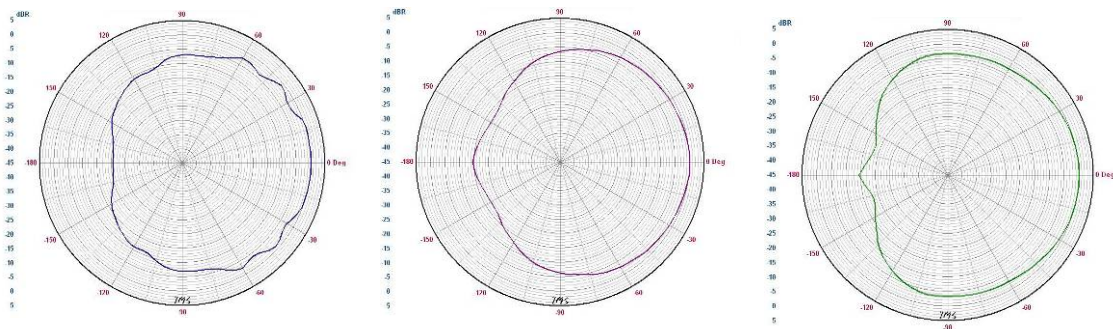

Fig.24a. Back energy rejection at 40Hz / 50 Hz / 63Hz

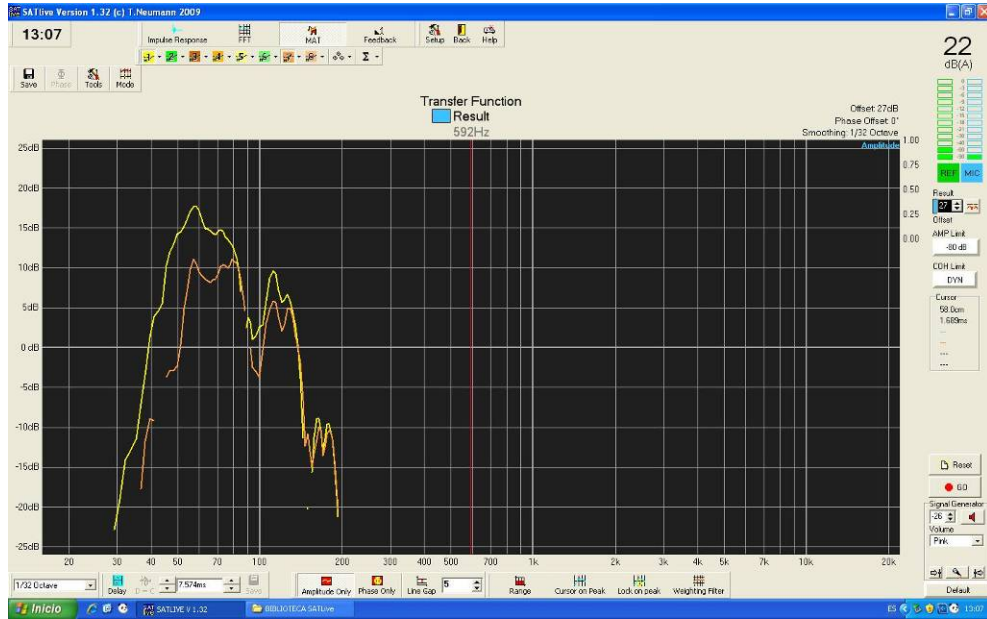

Fig.24b. X215W total back energy rejection. Yellow curve without central cardioid subwoofer; orange curve adding central cardioid subwoofer.

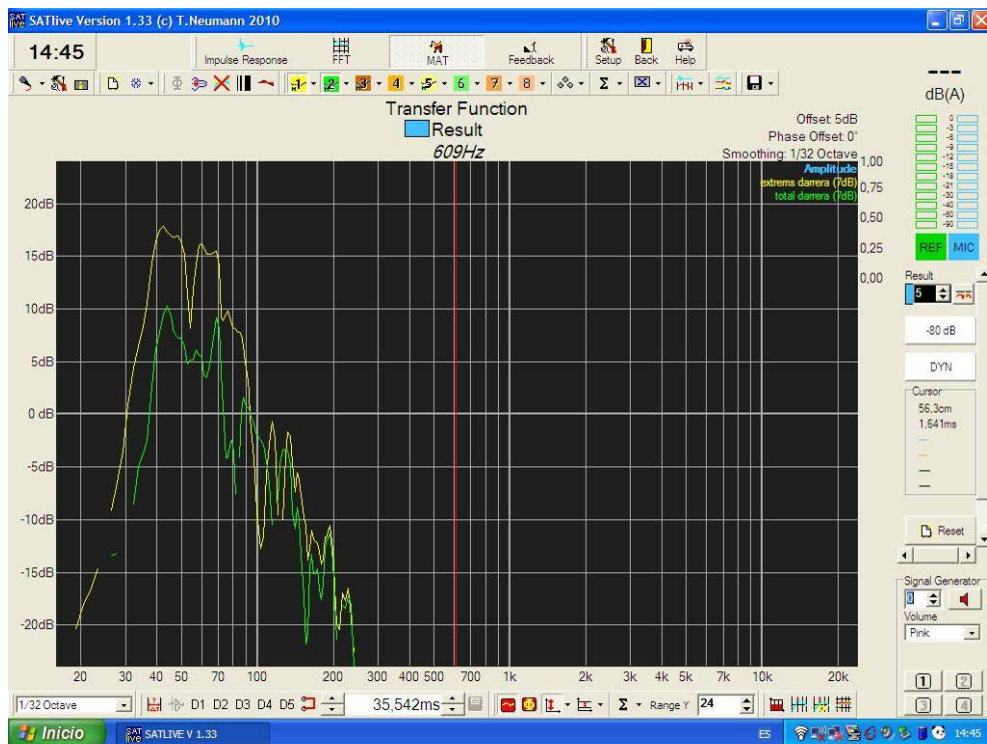

Fig.24c. X218W total back energy rejection. Yellow curve without central cardioid subwoofer; green curve adding central cardioid subwoofer.

IMPORTANT: If the user wants to adjust its own cardioid preset there is a specific manual to do it. Please, contact the sales department of Master Audio for more information.

7. CONNECTING

7.1. Parallel connection

Connect the signal (mixing desk output) to INPUT on the first unit. Use the LINK output to transfer the INPUT signal to the second unit and thus sequentially for further units. All of the units in this chain must be switched on.

For the mains connection in parallel use the cable with grey Neutrik PowerCon NAC3FCB at one end and the blue Neutrik PowerCon NAC3FCA at the other end.



Do not connect more than four X210A/X215W/X218W/X218W3K units using the AC Stacking output connector (this is the maximum number of units that can be linked). Nevertheless, we recommend to link two units whenever is possible.

Do not connect Xcellence Line Array series units in parallel using PowerCon-PowerCon without earth.

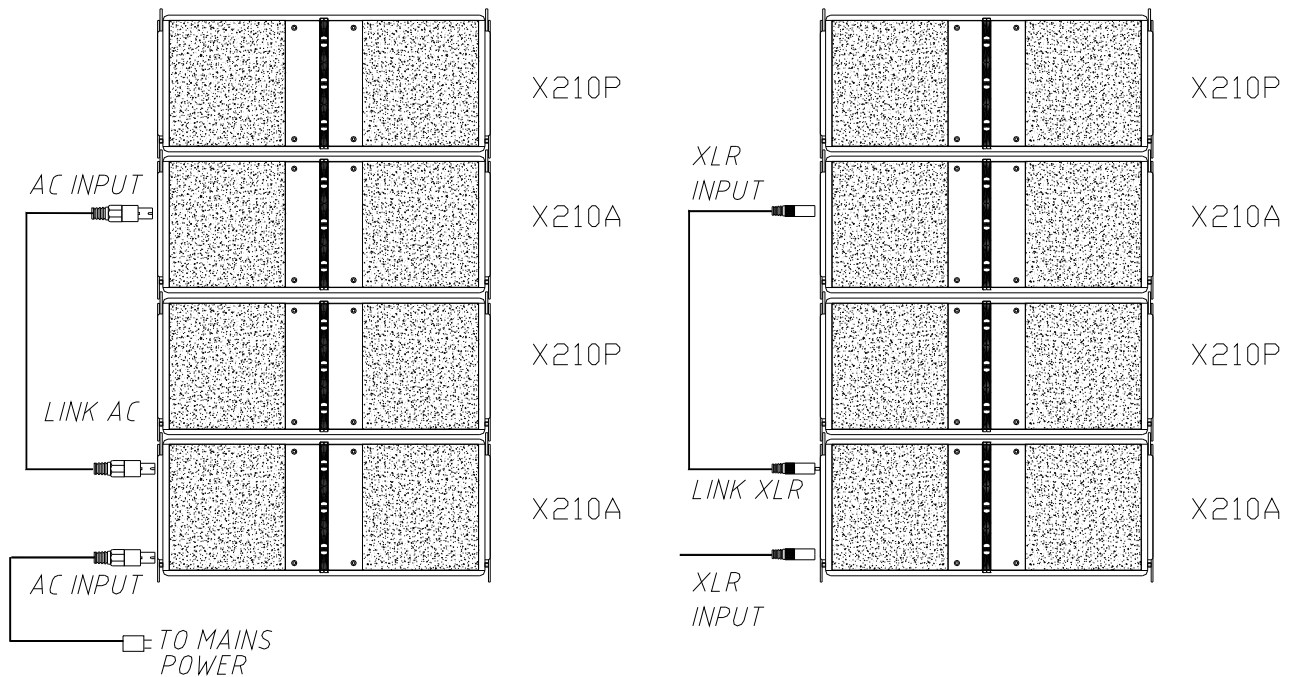

Fig.25. Parallel connection for the Xcellence Line Array series (signal and mains)

7.2. Parallel connection with subwoofers

You can connect X215W, X218W, X218W3K subwoofers in parallel with X210 cabinets. Please, follow the same parameters as explained in figure 25.

8. OVERVOLTAGE PROTECTION

The Xcellence series models incorporate protection against mains voltage overload.

In the mains input an electronic circuit compares the input voltage with a reference value. When the input exceeds 250 Volts, the circuit reacts by blocking the input tension until it returns to its correct limits (230V +/- 10%).

When the overvoltage LED lights up red, the unit stops running, until the correct voltage is re-established.

Generally the cause of such an anomaly tends to be a neutral voltage drop or incorrect connection of the equipment to 400V supply. Whenever the overvoltage LED lights up, check the tension of the electrical phases: other devices in the sound system are also at risk of electrical fault and severe damage.

9. MOUNTING AND INSTALLATION

Flying an Xcellence Line Array system is easy, fast and secure. To perform any operations related to flying the system, read the present document, and act on the warnings and advice given.

Only experienced installers with adequate knowledge of the system and local safety regulations should fly speaker cabinets.

It is the user's responsibility to ensure that the systems to be flown and the flying accessories (such as chains, eyebolts, lock pins...) comply with state and local regulations. They should be regularly inspected and replaced if in doubt.

When flying enclosures from ceiling support structures, extreme care should be taken to assure the load bearing capabilities of the structures. **Do not fly systems from unsafe structures.**

All flying accessories that are not supplied by Master Audio are the user's responsibility. Use at your own risk.

Remember that no risks should be taken with regards to public safety.

9.1. Description

Each X210 cabinet includes two structures on each side of the enclosure, one on the front-lateral side and the other on the back-lateral side. These structures are manufactured from 4mm black painted stainless steel; they are affixed to an internal plate with special crop resistant screws. There is a guide (front guide) assembled on the front-lateral structure (which is used to vertically join the cabinets); a second guide (back guide) assembled on the back-lateral structure is used to vertically join the cabinets and to tilt them.

Angles can be changed from 0° to 6°. To safely lock both guides, the lock pins supplied must be used.

Use the "SW" hole to join one X210 with one X215W or one X210 with TAX-210R frame.

To tilt the cabinets, both the back-lateral structure and the back guide must be used.

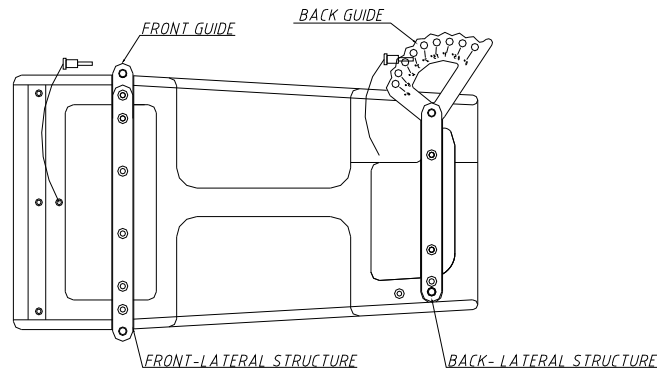

Fig.26. Flying hardware (lateral view)

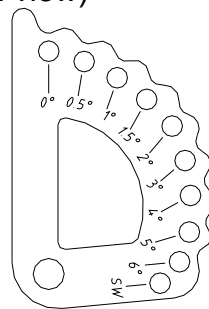

Fig.27. Back guide with graduation

To block the guides, highly resistant 8mm pins are used with ball safety lock.

To fly X210 units use the TA-X210R frame. It is made from stainless steel. It includes a centre bar to reinforce the whole structure. The bar has a series of holes that provide a pickup point for the steel chain slings or the hoists. The pickup point chosen will determine the tilt angle of the whole array system.

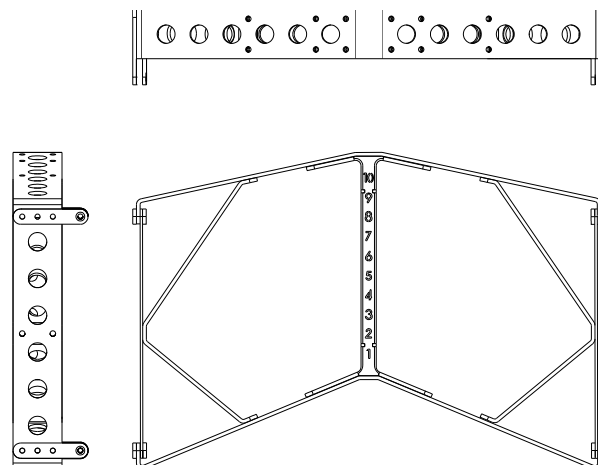

Fig.28. TA-X210R Frame

A shackle is included on the TA-X210R frame kit. It can be fitted into any of the centre bar holes (depending on the gravity centre of the configuration). The shackle can be also hung on the elevation motor of the system.

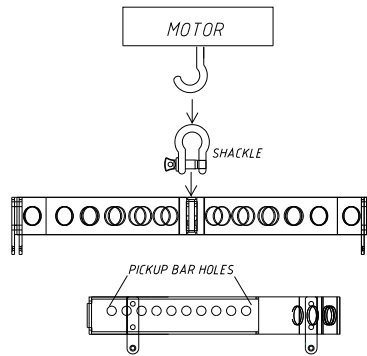

Fig.29. Flying configuration

The numbers on the central bar are those corresponding to Ease Focus2 calculations.

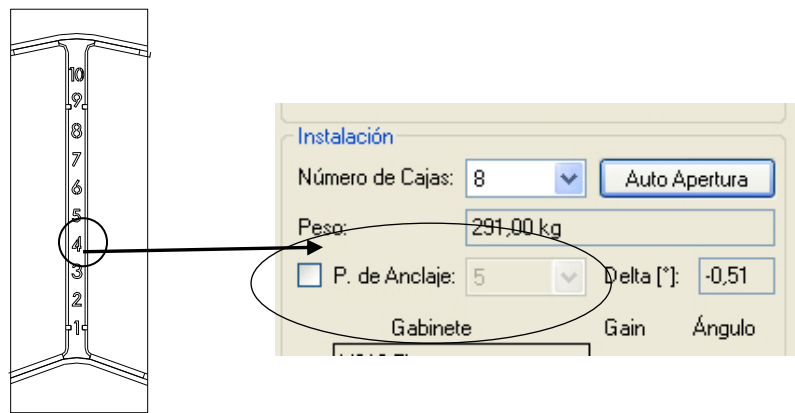

Fig.30. Pin points

9.2. X210 Flying

Use the back guide to choose the desired tilt angle (0°, 0.5°, 1°, 1.5°, 2°, 3°, 4°, 5° and 6°). Set the back guide between the back lateral structures of the cabinet that is placed above. Lock the guides with the safety pins.

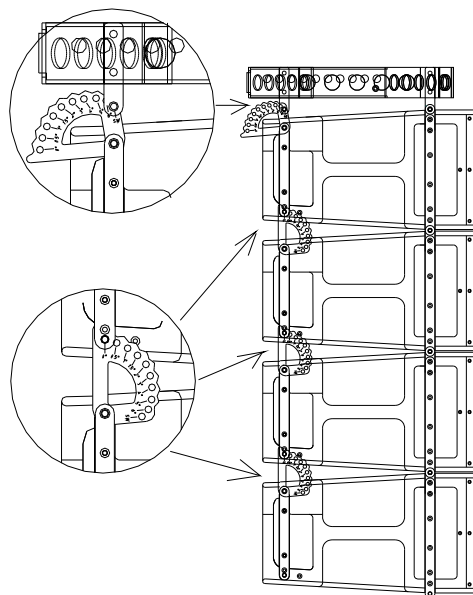

Fig.31. X210 Flying. Flat Line Array

(Cabinet 1 Back Guide = SW)
(Cabinet 2/3/4 Back Guide = 0°)

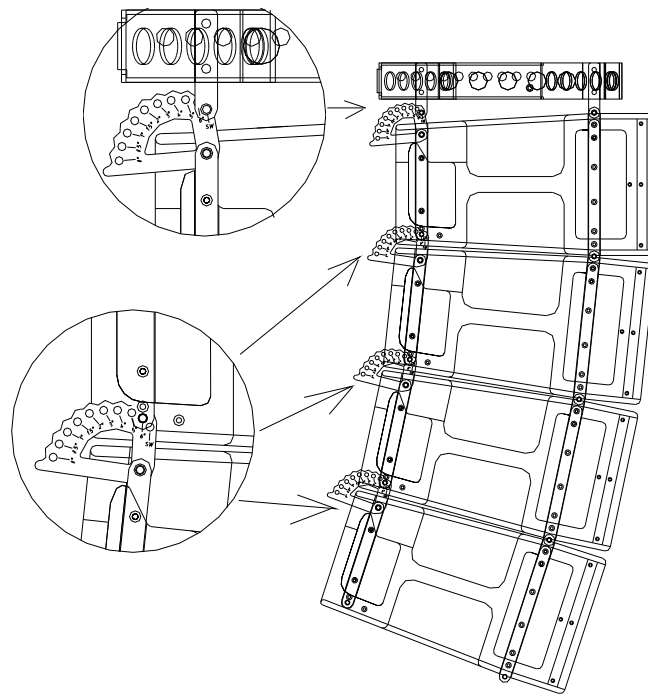

Fig.32. X210 Flying. 6° Curved Line Array (Cabinet 1 Back Guide = SW)
(Cabinet 2/3/4 Back Guide = 6°)

9.3. X215W Flying

Units are joined through the built-in guides of each cabinet. Use points 1 and 2 to block the system.

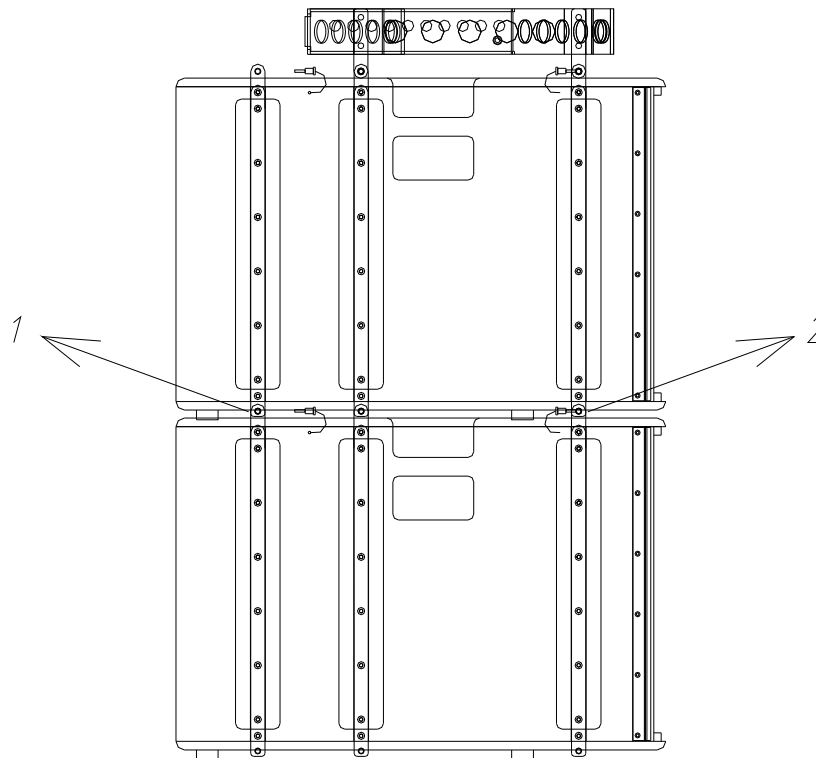

Fig.33. X215W Flying, two units

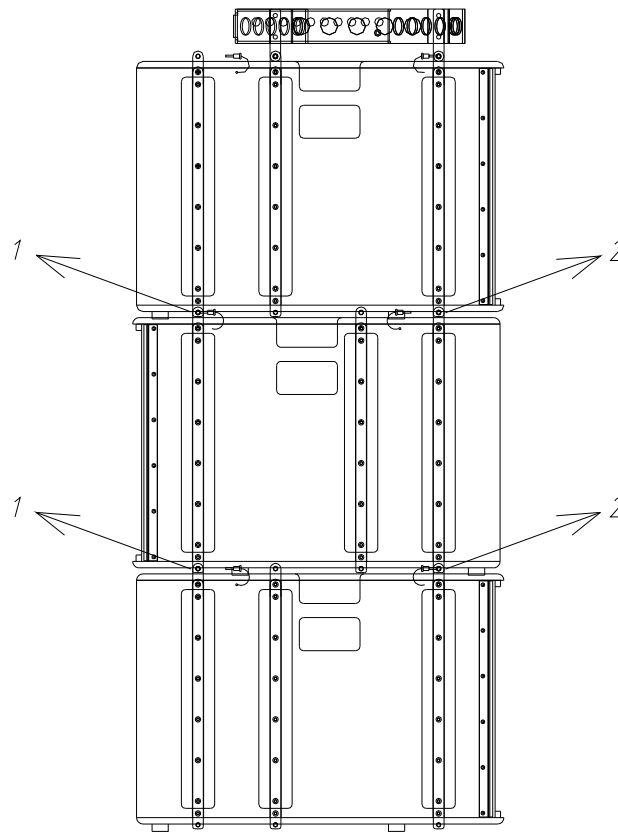

Fig.34. X215W Flying, three units in cardioid configuration

9.4. X210 + X215W Flying

It is useful to fly low frequency reinforcement units on the top of the system, as they are the heaviest enclosures. Place the subwoofers as has been explained in section 9.3. Join the last unit of X215W onto the first unit of X210 through the built-in hardware on the subwoofer.

Please select “SW” position on X210 back guide for the upper cabinet.

Follow section 9.2 to fly the rest of X210 units (choose between a flat line array or a curved line array).

We recommend 3-4 units of X215W for every 8 units of X210.

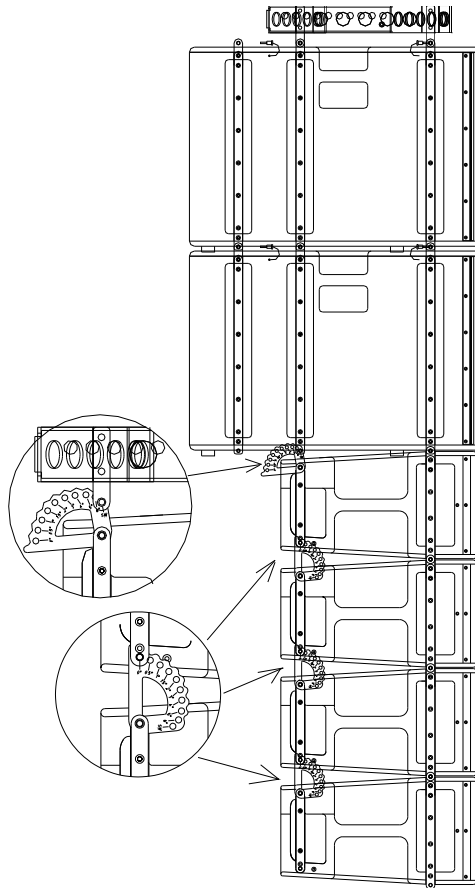

Fig.35. X210 + X215W flying, flat Line Array

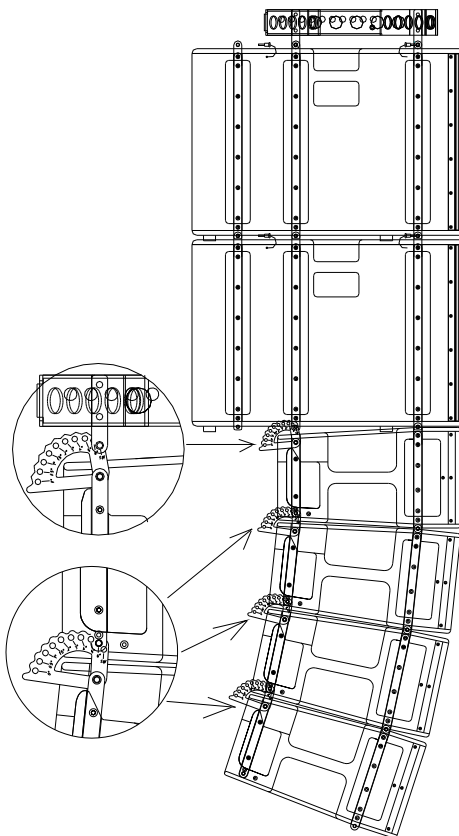

Fig.36. X210 + X215W Flying, curved Line Array

10. TECHNICAL SPECIFICATIONS

10.1. X210A specifications

Balanced line input:	2V (+8dBu)	Impedance:	20k ohm
Mains:	220V-240VAC / 50-60Hz (overvoltage protection >250V)		
Heavy duty musical program:	3.8A		
Frequency response Usable bandwidth (-10 dB)	70Hz-18kHz (LF_XTEND preset)		
Maximum output level (1m/continuous)	134 dB SPL		
Total amplifier power LOW HIGH	2400W 600W		
Nominal directivity Horizontal Vertical	120° defined by the array		

Components

LF 2 x 10" neodymium woofers (2.5" voice coil) with ICCR (Impedance Compensation Copper Ring)
HF 3 x 1"-exit neodymium drivers, PETP diaphragm (1.7" voice coil) mounted on our exclusive high frequency waveguide

Cabinet

Type	Symmetric, 120° V-shaped, bass-reflex
Front height	314 mm
Rear height	265mm
Width	764 mm
Depth	574 mm
Weight (net)	37 Kg
Connectors	2 x AC PowerCon (input, link) 2 x XLR (input, link) 2 x Ethercon RJ45 for Ethernet connection (input/link)
Material	Birch plywood, Steel front grilles with grey acoustic cloth
Finish	Hi-resistance weatherproof Polyurea paint
Rigging	Black painted stainless steel hardware

10.2. X210P specifications

Impedance

LOW	8 ohm
HIGH	8 ohm

Power Handling (r.m.s)

LOW	600 W
HIGH	150 W

Musical program

LOW	1200 W
HIGH	300 W

Frequency response

LF Usable bandwidth (-10 dB)	70 Hz - 2 kHz
HF Usable bandwidth (-10 dB)	1k6Hz - 18kHz

Sensitivity

LF (2.83V @ 1m)	102 dB SPL
HF (2.83V @ 1m)	110 dB SPL

Nominal directivity

Horizontal	120°
Vertical	defined by the array

Components

LF 2 x 10" neodymium woofers (2.5" voice coil) with ICCR (Impedance Compensation Copper Ring)
 HF 3 x 1"-exit neodymium drivers, PETP diaphragm (1.7" voice coil) mounted on our exclusive high frequency waveguide

Cabinet

Type	Symmetric, 120° V-shaped, bass-reflex
Front height	314 mm
Rear height	265mm
Width	764 mm
Depth	574 mm
Weight (net)	33 Kg
Connectors	2 x SPEAKON +1/-1 LOW / +2/-2 HIGH
Material	Birch plywood, Steel front grilles with grey acoustic cloth
Finish	Hi-resistance weatherproof Polyurea paint
Rigging	Black painted stainless steel hardware

10.3. X215W specifications

Balanced line input: 1V (+2dBu) **Impedance:** 20k ohm

Mains: 220V-240VAC / 50-60Hz (overvoltage protection >250V)

Heavy duty musical program: 3.5A

Frequency response

Usable bandwidth (-10 dB) 32Hz-130Hz

Maximum output level (1m/continuous) 135 dB SPL

Amplifier power 2400W

Nominal directivity

Horizontal omnidirectional
Vertical omnidirectional

Components

LF 2 x 15" neodymium woofers (4" voice coil) with rubber surround

Cabinet

Type 6th-order bandpass
Height 600 mm
Width 764 mm
Depth 859 mm
Weight (net) 79 Kg
Connectors 2 x AC PowerCon (input, link)
2 x XLR (input, link)
2 x Ethercon RJ45 for Ethernet connection (input/link)
Material Birch plywood, Steel front grilles with grey acoustic cloth
Finish Hi-resistance weatherproof Polyurea paint
Rigging Black painted stainless steel hardware

10.4. X218W specifications

Balanced line input: 1V (+2dBu) **Impedance:** 20k ohm

Mains: 220V-240VAC / 50-60Hz (overvoltage protection >250V)

Heavy duty musical program: 3.5A

Frequency response
Usable bandwidth (-10 dB) 30Hz-120Hz

Maximum output level (1m/continuous): 137 dB SPL

Amplifier power 2400W

Nominal directivity
Horizontal omnidirectional
Vertical omnidirectional

Components
LF 2 x 18" neodymium woofers (4" voice coil)

Cabinet
Type Bass-reflex
Height 1046 mm
Width 740 mm
Depth 780 mm
Weight (net) 98 Kg
Connectors 2 x AC PowerCon (input, link)
2 x XLR (input, link)
2 x Ethercon RJ45 for Ethernet connection (input/link)
Material Birch plywood, Steel front grilles with grey acoustic cloth
Finish Hi-resistance weatherproof Polyurea paint
Rigging -----

10.5. X218W3K specifications

Balanced line input: 1V (+2dBu) **Impedance:** 20k ohm

Mains: 220V-240VAC / 50-60Hz (overvoltage protection >250V)

Heavy duty musical program: 4.2A

Frequency response
Usable bandwidth (-10 dB) 28Hz-120Hz

Maximum output level (1m/continuous): 138 dB SPL

Amplifier power 3000W

Nominal directivity
Horizontal omnidirectional
Vertical omnidirectional

Components

LF 2 x 18" neodymium woofers (4.5" voice coil)

Cabinet

Type Bass-reflex
Height 1046 mm
Width 740 mm
Depth 780 mm
Weight (net) 104.5 Kg
Connectors 2 x AC PowerCon (input, link)
2 x XLR (input, link)
2 x Ethercon RJ45 for Ethernet connection (input/link)
Material Birch plywood, Steel front grilles with grey acoustic cloth
Finish Hi-resistance weatherproof Polyurea paint
Rigging -----

11. FLYING & STACKING ACCESSORIES

a) X210 Flying

You need:

TA-X210R frame

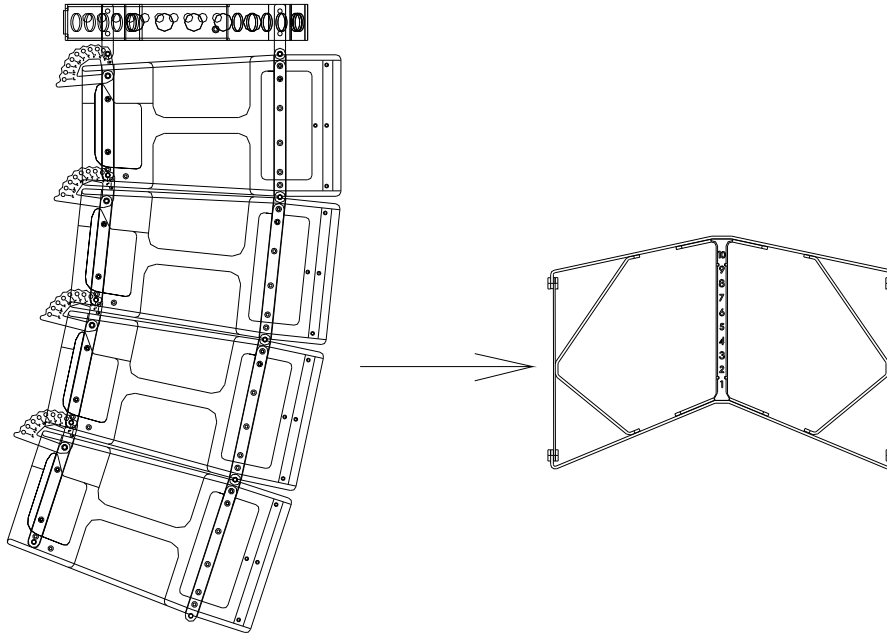

b) X210 + X215W Flying

You need:

TA-X210R frame

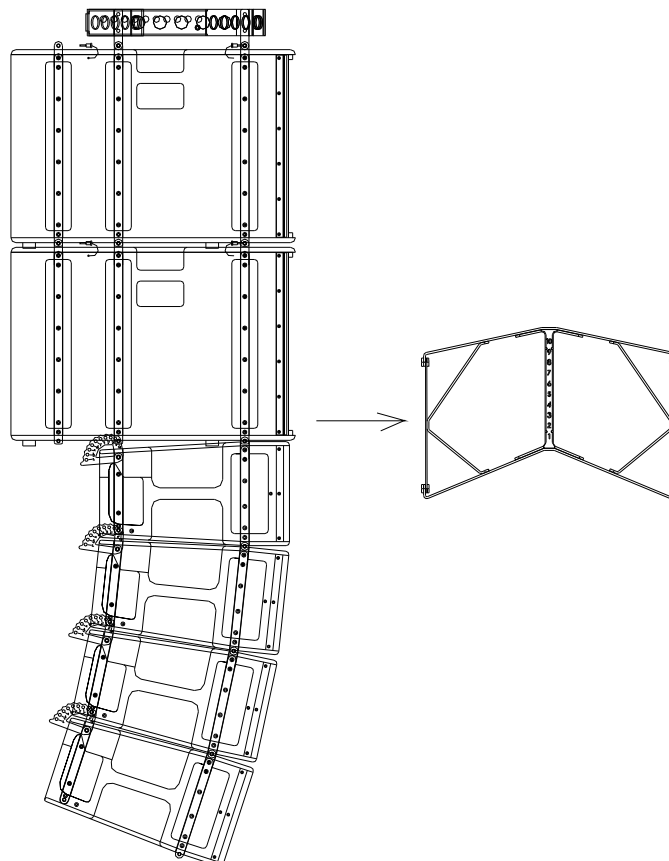

c) X210 Stacking on X215W

You need:

ST-X215 kit stacking

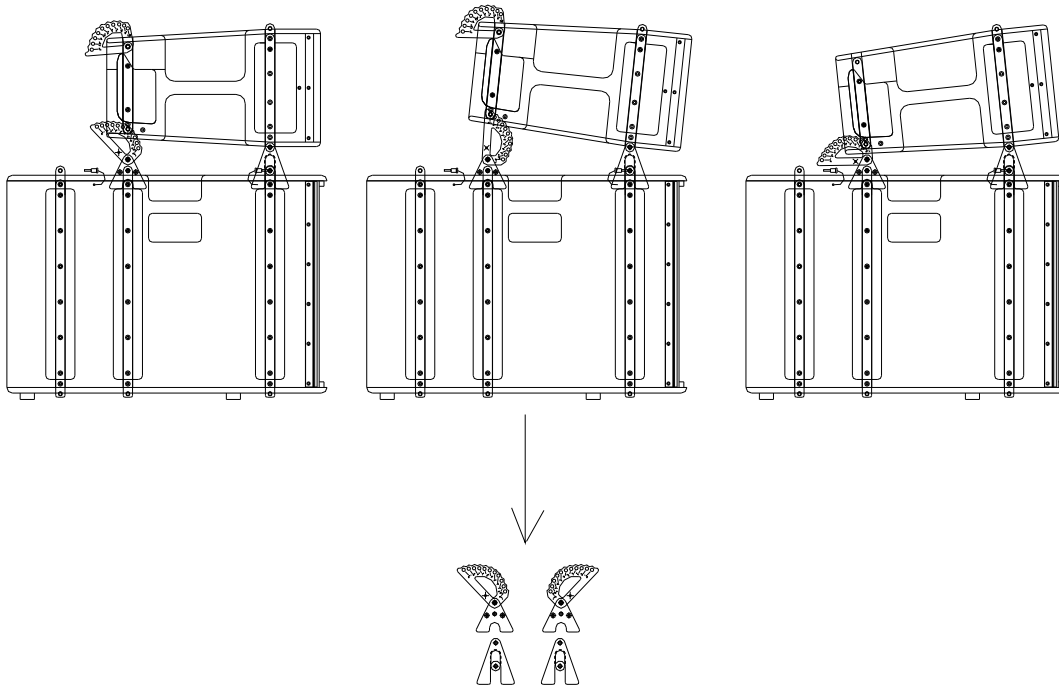

d) X210 Stacking on X218W/X218W3K

You need:

FR-X218 kit stacking

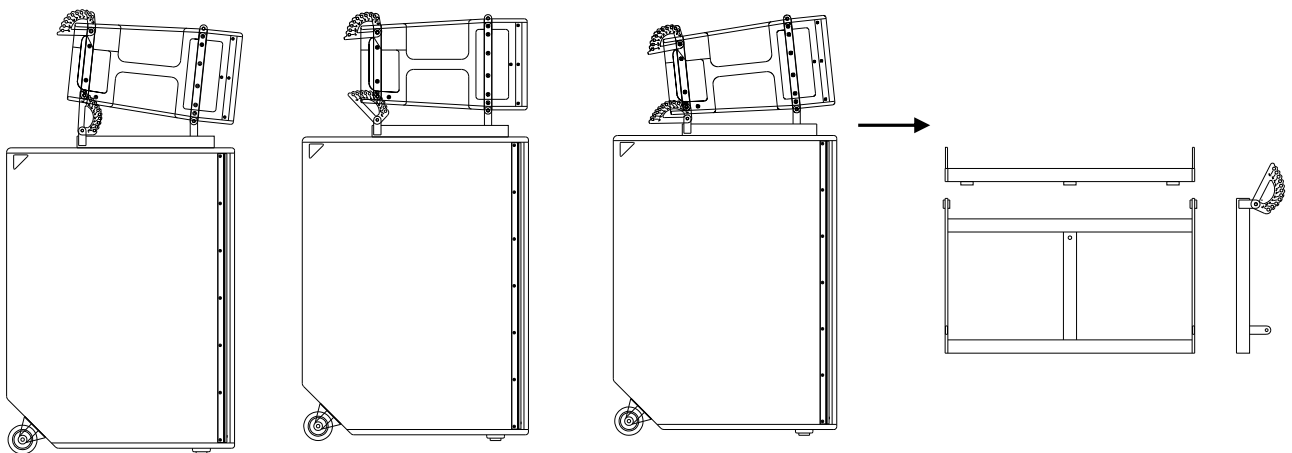

12. TIME ALIGNMENT IN PA SYSTEMS

In common PA systems the frequency range is divided into different ranges which are reproduced using different cabinets (subwoofers for the bass range and top cabinets for the mid-high range). This means different locations and positions of the sound sources.

This leads to some interferences in the crossover range, causing notches and peaks in that area. Time alignment (delay) tries to adjust the arrival time of sound so that in the crossover area it arrives at the same time.

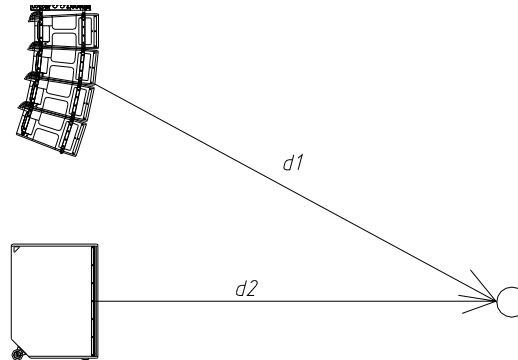

Fig.37. This system is not completely aligned because d_1 and d_2 are not equal.

If we do not put a delay on the subwoofer cabinets we may notice a dramatic cancellation in the frequency range being shared by both cabinets or in the crossover frequency between the subwoofer units and the top units.

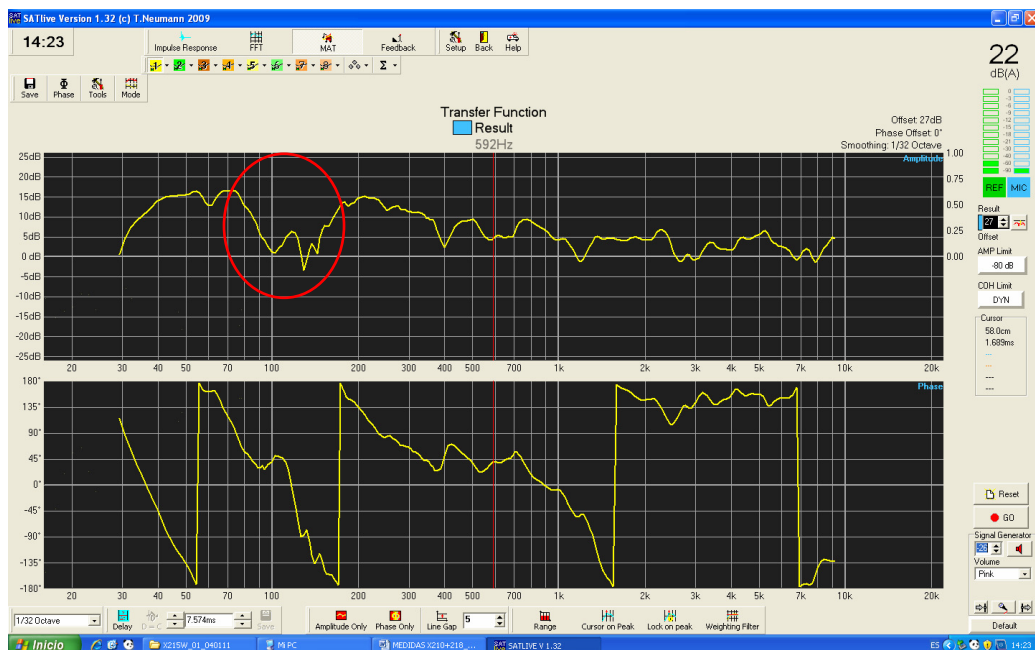

Fig.38. Magnitude and phase response of the complete unaligned system (with no delay)

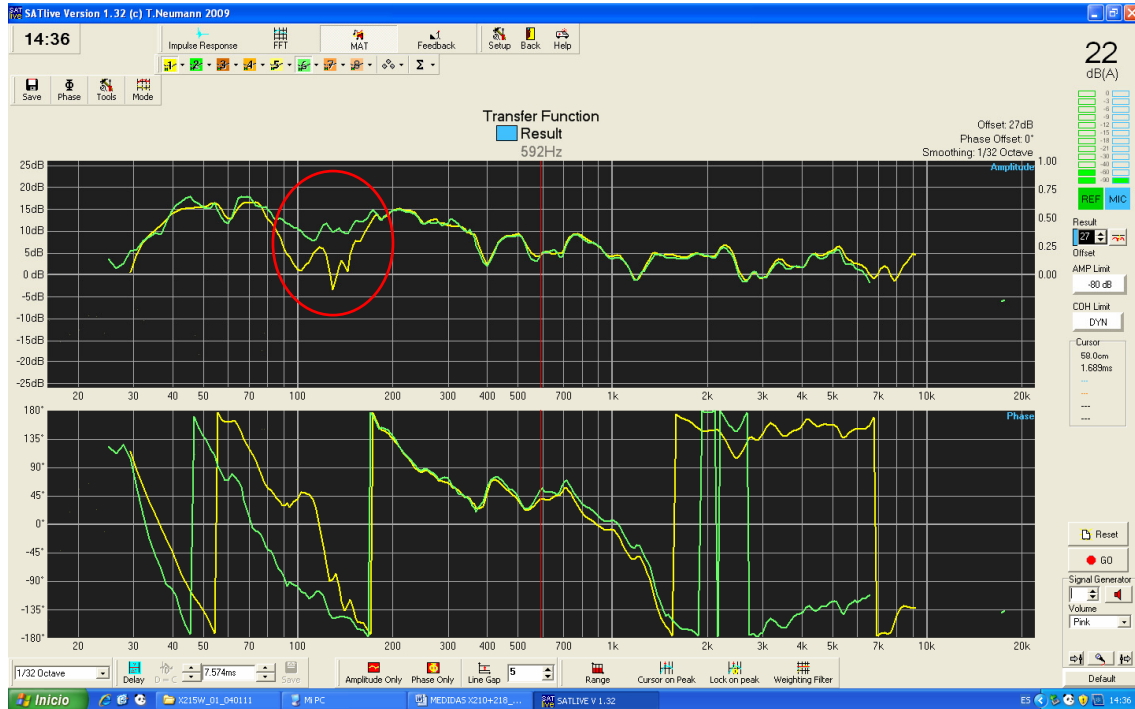

Fig.39. Magnitude and phase response of the complete aligned system (with delay), green curve

The delay value that must be introduced into the subwoofers depends on many factors such as the position of the subwoofers with respect to the top boxes and the height of the top boxes with respect to the subwoofers. That is the reason why it is very difficult to establish a functioning single value for all applications.

IMPORTANT: If the user wants to adjust its own system there is a specific manual to do it (“Time alignment in PA systems”). Please, contact the sales department of Master Audio for more information.

13. TROUBLESHOOTING

No power

- Check the device is connected to mains
- Check mains cable is in good condition.

No sound

- Check with the indicators that the signal is being sent from the mixer.
- Check that the signal cables are in good condition and connected at both ends
- The mixer output level must not be at minimum.
- Check that the mixer is not in Mute mode.

Distorted output signal

- The system is being saturated with a very high input signal, frequently caused by the mixer overload. Check the output level or mixer gain channels.

Poor bass levels

- Check the polarity on the signal connections between the mixer and cabinets. If any of the Pins (1, 2 or 3) have been inverted at the cable ends, this will cause significant performance and sound quality loss.

Noise and Hum

- Check that all the connections to the active units are in good condition.
- Avoid intertwining between mains supply cables or proximity to transformers or Electromagnetic (EMI) emitting devices.
- Check there is no light intensity regulator in the same AC circuit as the unit. ALWAYS connect the sound and light circuits in different phases.

Overvoltage LED light (RED)

- Check that the mains voltage is within the limits (230+/-10%), 50/60 Hz